



AKAI

DVD PLAYER

Model:
DV-P4797KDMC

SERVICE MANUAL

Daewoo DA Service Manual

Table of Contents

	Page
General Section.....	2-5
Caution/Warnings	
Safe Warnings	
Precautions	
Software Upgrade	
Circuit Diagram and Component Layout.....	6-26
MPEG IC Block Diagrams	
Power supply Circuit Diagram and Component Layout	
MPEG Circuit Diagram and Component Layout	
Front panel Circuit Diagram and Component Layout	
Servicing Procedures.....	27-33
Power Supply Trouble Service Flow Chart	
Read Disc Trouble Service Flow Chart	
Video Trouble Service Flow Chart	
Composite Analogy Audio Trouble Service Flow Chart	
Digital Audio Trouble Service Flow Chart	
Front Control Trouble Service Flow Chart	
Remote Control Trouble Service Flow Chart	
Parts List.....	34-37
Power Part List	
MPEG Part List	
Front Panel Part List	
Karaoke Panel Part List	

1. General Section

1.1 Cautions/Warnings

1.1.1 Product Safety Notice

Parts marked with the symbol  in the schematic diagram have critical characteristics.

Use **ONLY** replacement parts recommended by the manufacturer.

It is recommended that the unit be operated from a suitable DC supply or batteries during initial check out procedures.



WARNING HIGH VOLTAGE INSIDE TO PREVENT ELECTRICAL SHOCK DO NOT REMOVE ANY COVER OR SCREW. REFER ALL SERVICING TO QUALIFIED SERVICE PERSONNEL. DO NOT ALLOW THIS PRODUCTION BE EXPOSED TO RAIN OR MOISTURE. DISCONNECT THIS MAINS PLUG FROM THE SUPPLY SOCKET WHEN NOT IN USE.

1.1.2 Leakage Current Check/Resistance Check

Before returning the unit to the customer, make sure you make either (1) a leakage current check or (2) a line to insulated resistance check.

If the leakage current exceeds 0.5 milliamps, or if the resistance from chassis to either side of the power cord is less than 240 K ohms, the unit is defective.

WARNING: DO NOT return the unit to the customer until the problem is located and corrected.

1.2. Safe Warnings

1.2.1. Protection of Eyes from Laser Beam

To protect eyes from invisible laser beam during servicing
DO NOT LOOK AT THE LASER BEAM

1.2.2 Laser Caution

CAUTION

Adjusting the knobs, switches, and controls, ect. Or taking actions not specified herein may result in a harmful emission of laser beams. This CD Changer must be adjusted and repaired only by qualified service personnel.

CAUTION- INVISIBLE LASER RADIATION WHEN OPEN AND INTERLOCKS DEFEATED AVOID EXPOSURE TO BEAM.
VORSICHTI- UNSICHTBARE LASERSTRAHLUNG TRITTAUS. WENN DECKEL GEOFFNET UND WENN SICHERHEITSVERRIEGELUNG UBERBRÜCKT IST. NICHT DEM STRAHL AUSSETZEN!
VARNING- OSYNLIG LASERSTRÅLNING NÄR DENNA DEL ÄR ÖPPNAD OCH SPÄRR ÄR URKOPPLAD STRÅLEN ÄR FARLIG.
ADVARSEL- USYNLIG LASERSTRÅLING VED ÅBNING NÄR SIKKERHEDSAFBRYDERE ER UDE AF FUNKTION. UNDGÅ UDSÆTTELSE FOR STRÅLING.

CLASS 1 LASER PRODUCT
LUOKAN 1 LASERLAITE
KLASS 1 LASERAPPARAT

THIS IS COMPACT DISC PLAYER IS CLASSIFIED AS A CLASS LASER PRODUCT.
THE CLASS 1 LASER PRODUCT LABEL IS LOCATED ON THE REAR EXTERIOR.

1.3. Precautions

1.3.1. ESD Precautions in Repairing

1.3.1.1 Do not apply excessive pressure on the mechanical parts (moving parts), including the Pickup Block, as extremely high mechanical precision or required in these parts.

1.3.1.2 When soldering the microprocessor and signal processing IC's, use a ceramic soldering iron or a soldering iron whose metal part is grounded since they are not resistant to static electricity.

1.3.1.3 When removing the solder or soldering the laser shorting lands for the Pickup Block, use a ceramic soldering iron or a soldering iron whose metal part is grounded since the laser diode or not resistant to static electricity.

1.3.2. DVD Loading Unit Precautions When handing the Mechanism Block

1.3.2.1 Do not loosen any screws in the Pickup Block.

1.3.2.2 Do not adjust any screws in the Mechanism Block except for “Tilt Adjust Screws” , as they are adjusted precisely at the factory.

1.3.2.3 Replacement of the Pickup Block is impossible. Always replace the Traverse Ass’ s when the Pickup Block needed to be replace . Do not touch the lens or lens holder of the Pickup Block.

1.3.2.4 The Guide Rails of the Pickup Block are greased. Take care when handing.

1.3.2.5 When you try to slide the Pickup Block, do not press or pull it directly, Always turn the dive gears with your fingers.

1.3.2.6 Be sure that the anti-slipping rubber on the turnable or clean. If there is dust or it is greasy, clean the part with the liquid that contains 50% each of alcohol and water.

1.3.2.7 When removing the Mechanism P.C.B. Ass’ s, you need to short-circuit the laser diode shorting lands beforehand.

1.4. Software Upgrade

You can upgrade DVD player using the software we provide as following step:

The CD-R update is below lists:

First, burn CDR for upgrade. Dummy files are needed minimum 20Mbytes.

The burning software is Nero burning soft:

1. Volume name: WESTLAKE

2. Files name and type: ZORAN.BIN (This file must locate Root directory)

3. CD-R burn type(formate): ISO9660

Model 1

ISO1 (level 1)

don’ t choice Jolient

don’ t choice loosen ISO strict

Notice: WESTLAKE and DWDVDP.BIN are upper case.

The CD upgrade process:

After the servo read the CD-R data ,Show Message on TV :

UPGRADE FILE DETECTED

UPGRADE ?

PRS CHOOSE (1-8Bit 2-16Bit)

Press 1 key , Show Message on TV

UPGRADE FILE DETECTED
UPGRADE ?
File Copy

The tray is automatic to open, take disc away.

UPGRADE FILE DETECTED
UPGRADE ?
Upgrading

At this time, please wait a few minutes, DVD is downloading code to flash, After Logo will be show on TV again, the update process finish.

Notice: During upgrading , don' s turn off power.

Displaying the software Version Number

After opening the tray, press the following keys on the remote control ,

DISPLAY → ▲ (Up) → ▼ (Down) → ◀ (Left) → ▶ (Right)

then the software version number appears.



Specifications are subject to change without notice

MTK

MT1389D

Progressive-Scan DVD Player SOC

MediaTek MT1389D is a cost-effective DVD system-on-chip (SOC) which incorporates advanced features like high quality TV encoder and state-of-art de-interlace processing. The MT1389D enables consumer electronics manufacturers to build high quality, feature-rich DVD players, portable DVD players or any other home entertainment audio/video devices.

World-Leading Technology: Based on MediaTek's world-leading DVD player SOC architecture, the MT1389D is the 3rd generation of the DVD player SOC. It integrates the MediaTek 2nd generation front-end analog RF amplifier and the Servo/MPEG AV decoder.

Incredible Audio/Video Quality: The progressive scan of the MT1389D utilized advanced motion-adaptive de-interlace algorithm to achieve the best movie/video playback. It also supports a 3:2 pull down algorithm to give the best film effect. The 108MHz/12-bit video DAC provides users a whole new viewing experience.

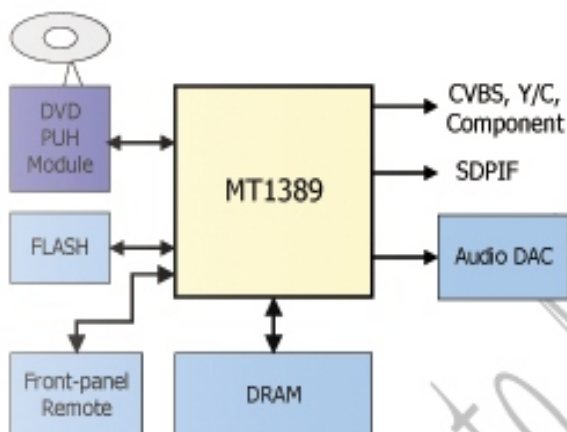

DVD Player System Diagram Using MT1389D

Key Features

- RF/Servo/MPEG Integration
- High Performance Audio Processor
- Progressive Scan
- 108MHz/12-bit, 4 CH TV Encoder

Applications

- Standard DVD Players
- Portable DVD Players
- TV/DVD Combo Systems

General Feature List

- Super Integration DVD player single chip
 - High performance analog RF amplifier
 - Servo controller and data channel processing
 - MPEG-1/MPEG-2/JPEG video
 - Dolby AC-3/DTS Decoder
 - Unified memory architecture
 - Versatile video scaling & quality enhancement
 - OSD & Sub-picture
 - Built-in clock generator
 - Built-in high quality TV encoder
 - Built-in progressive video processor
 - Audio effect post-processor
- High Performance Analog RF Amplifier
 - Programmable fc
 - Dual automatic laser power control
 - Defect and blank detection
 - RF level signal generator
- Speed Performance on Servo/Channel Decoding
 - DVD-ROM up to 4XS
 - CD-ROM up to 24XS
- Channel Data Processor
 - Digital data slicer for small jitter capability
 - Built-in high performance data PLL for channel data demodulation
 - EFM/EFM+ data demodulation
 - Enhanced channel data frame sync protection & DVD-ROM sector sync protection
- Servo Control and Spindle Motor Control
 - Programmable frequency error gain and phase error gain of spindle PLL to control spindle motor on CLV and CAV mode
 - Built-in ADCs and DACs for digital servo control
 - Provide 2 general PWM
 - Tray control can be PWM output or digital output
- Embedded Micro controller
 - Built-in 8032 micro controller
 - Built-in internal 373 and 8-bit programmable lower address port
 - 1024-bytes on-chip RAM
 - Up to 2M bytes FLASH-programming
- interface
 - Supports 5/3.3-Volt. FLASH interface
 - Supports power-down mode
 - Supports additional serial port
- DVD-ROM/CD-ROM Decoding Logic
 - High-speed ECC logic capable of correcting one error per each P-codeword or Q-codeword
 - Automatic sector Mode and Form detection
 - Automatic sector Header verification
 - Decoder Error Notification Interrupt that signals various decoder errors
 - Provide error correction acceleration
- Buffer Memory Controller
 - Supports 16Mb/32Mb/64Mb SDRAM
 - Supports 16-bit SDRAM data bus
 - Provides the self-refresh mode SDRAM
 - Block-based sector addressing
- Video Decode
 - Decodes MPEG1 video and MPEG2 main level, main profile video (720/480 and 720x576)
 - Smooth digest view function with I, P and B picture decoding
 - Baseline, extended-sequential and progressive JPEG image decoding
 - Support CD-G titles
- Video/OSD/SPU/HLI Processor
 - Arbitrary ratio vertical/horizontal scaling of video, from 0.25X to 256X
 - 65535/256/16/4/2-color bitmap format OSD,
 - 256/16 color RLC format OSD
 - Automatic scrolling of OSD image
- Audio Effect Processing
 - Dolby Digital (AC-3) decoding
 - DTS decoding
 - MPEG-1 layer 1/layer 2 audio decoding
 - MPEG-2 layer1/layer2 2-channel audio
 - High Definition Compatible Digital (HDCD)
 - Windows Media Audio (WMA)
 - Advanced Audio Coding (AAC)
 - Dolby ProLogic II
 - Concurrent multi-channel and downmix out
 - IEC 60958/61937 output
 - PCM / bit stream / mute mode



- Custom IEC latency up to 2 frames
- Pink noise and white noise generator
- Karaoke functions
 - Microphone echo
 - Microphone tone control
 - Vocal mute/vocal assistant
 - Key shift up to +/- 8 keys
 - Chorus/Flanger/Harmony/Reverb
- Channel equalizer
- 3D surround processing include virtual surround and speaker separation

- TV Encoder
 - Four 108MHz/12bit DACs
 - Support NTSC, PAL-BDGHINM, PAL-60
 - Support 525p, 625p progressive TV format

- Automatically turn off unconnected channels
- Support PC monitor (VGA)
- Support Macrovision 7.1 L1, Macrovision 525P and 625P
- CGMS-A/WSS
- Closed Caption

- Progressive Scan Video
 - Automatic detect film or video source
 - 3:2 pull down source detection
 - Advanced Motion adaptive de-interlace
 - Minimum external memory requirement

- Outline
 - 216-pin LQFP package
 - 3.3/1.8-Volt. Dual operating voltages

Functional Block Diagram

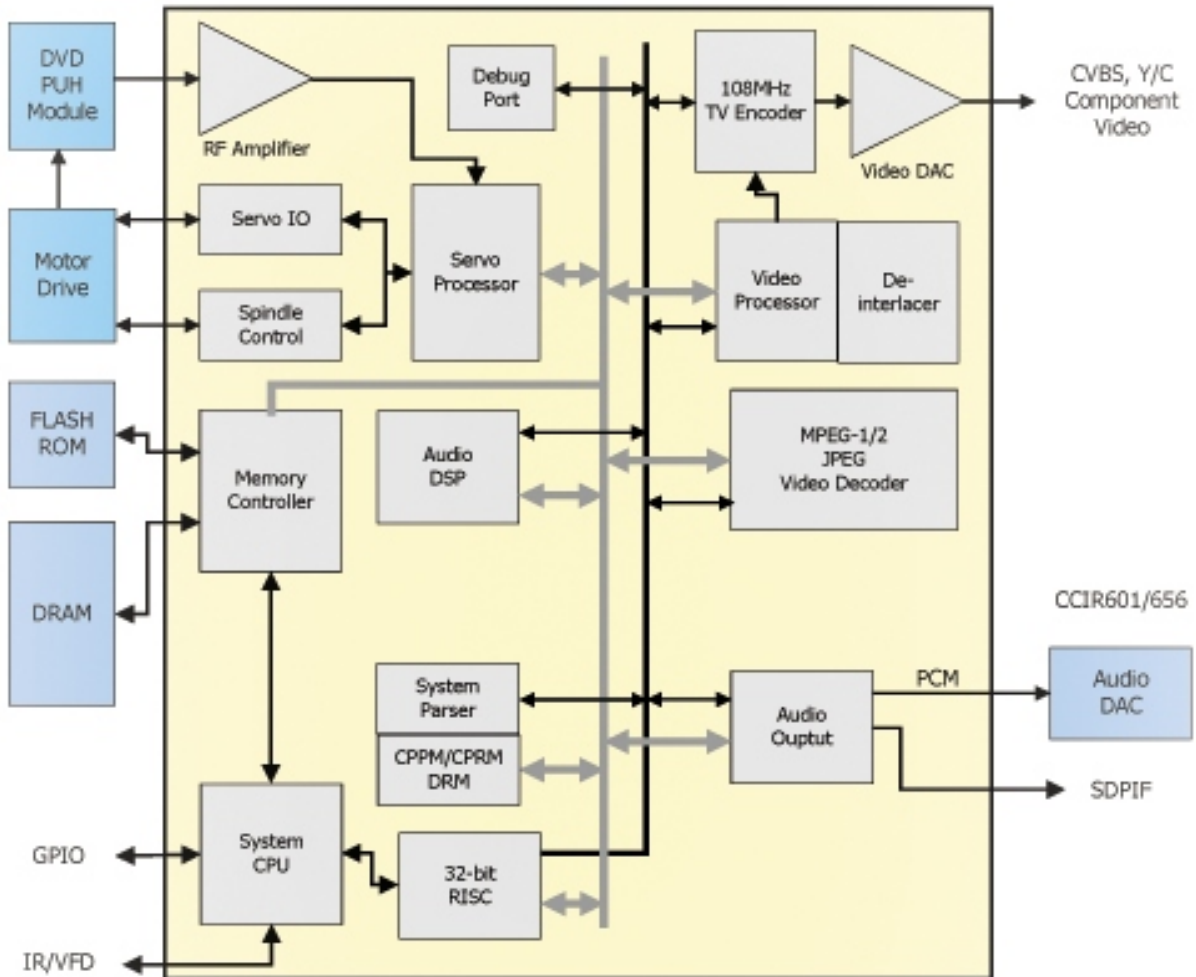



Electrical Characteristics

Absolute Maximum Rating

Symbol	Parameters	Value	Unit
VDD3	3.3V Supply voltage	-0.5 to 4.6	V
VDD2	1.8V Supply voltage	-0.5 to 3.0	V
VDDA	Analog Supply voltage	-0.5 to 4.6	V
VIN(3.3V)	Input Voltage (3.3V IO)	VSS-1.0 to 3.63	V
VIN(5V-tolerance)	Input Voltage (5V-tolerance IO)	VSS-1.0 to 5.5	V
VOUT	Output Voltage	-0.3 to VDD3+0.3	V
Ts	Storage Temperature	-40 to 150	C
Ta	Ambient Temperature	0 to 70	C

DC Characteristics

Symbol	Parameters	Min	Typ	Max	Unit
VIH (1.8V)	Input voltage high (1.8V IO)	1.05	-	-	V
VIL (1.8V)	Input voltage low (1.8V IO)	-	-	0.69	V
VIH (3.3V)	Input voltage high (3.3V IO)	2.0	-	-	V
VIL (3.3V)	Input voltage low (3.3V IO)	-	-	0.8	V
VOH (1.8V)	Output voltage high (1.8V IO)	1.22	-	-	V
VOL (1.8V)	Output voltage low (1.8V IO)	-	-	0.4	V
VOH (3.3V)	Output voltage high (3.3V IO)	2.4	-	-	V
VOL (3.3V)	Output voltage low (3.3V IO)	-	-	0.4	V
Tj	Junction Operation Temp.	0		115	C
I _{IH}	High level input current			10	uA
I _{IL}	Low level input current	-10			uA
PD	Power dissipation		1.0		W
P _{Down}	Power down mode			0.1	W

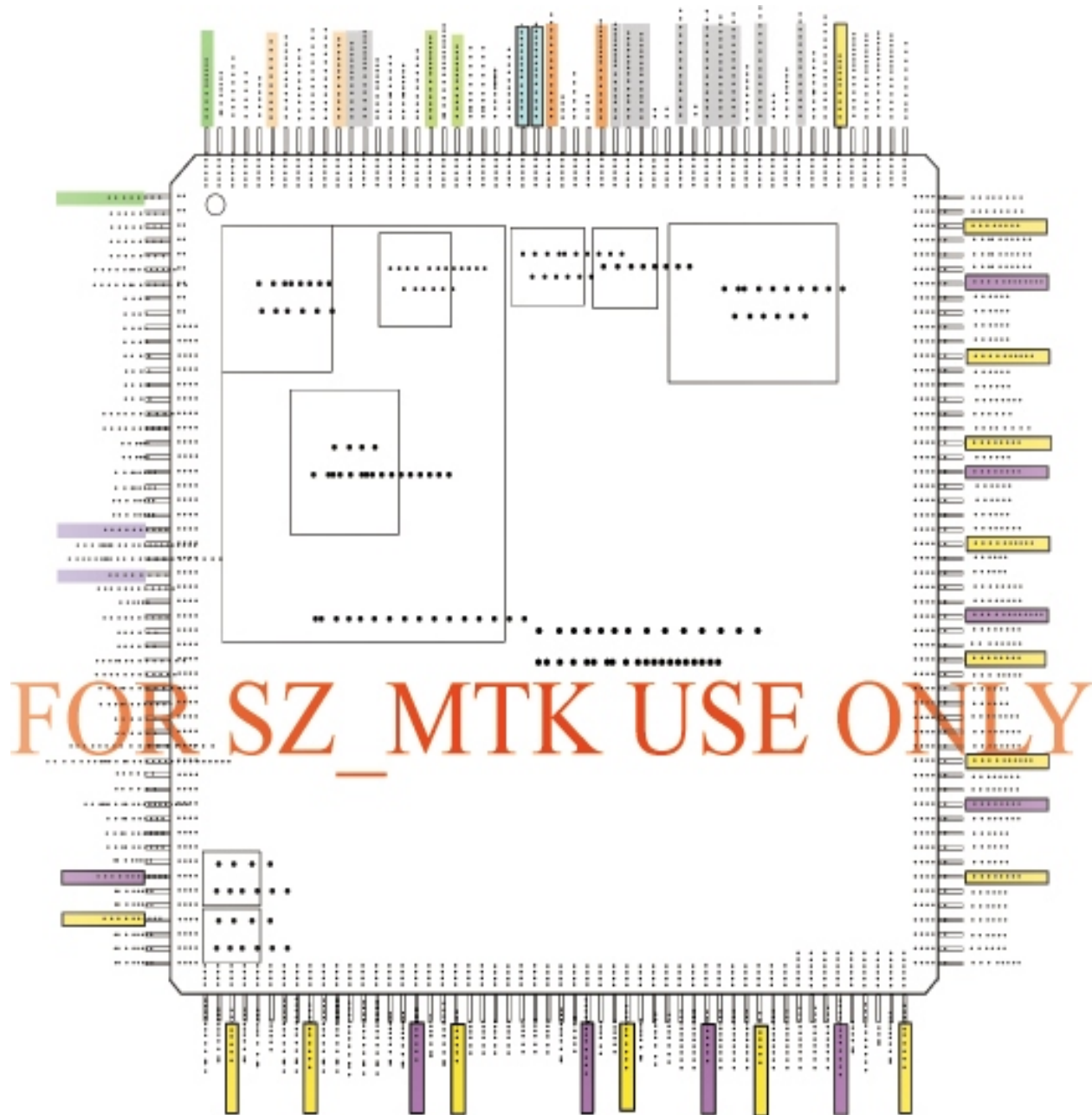

Abbr. :

SR : Slew Rate

PU : Pull Up

PD : Pull Down

SMT : Schmitt Trigger

4MA~16MA : Output buffer driving strength.

Pin	Main	Alt.	Type	Description
RF Interface (26)				
191	RFGND18		Ground	Analog ground
192	RFVDD18		Power	Analog power 1.8V
212	OSP		Analog output	RF Offset cancellation capacitor connecting
213	OSN		Analog output	RF Offset cancellation capacitor connecting
214	RFGC		Analog output	RF AGC loop capacitor connecting for DVD-ROM
215	IREF		Analog Input	Current reference input. It generates reference current for RF path. Connect an external 15K resistor to this pin and AVSS.
216	AVDD3		Power	Analog power 3.3V
1	AGND		Ground	Analog ground
2	DVDA		Analog Input	AC coupled input path A
3	DVDB		Analog Input	AC coupled input path B
4	DVDC		Analog Input	AC coupled input path C
5	DVDD		Analog Input	AC coupled input path D
6	DVDRFIP		Analog Input	AC coupled DVD RF signal input RFIP
7	DVDRFIN		Analog Input	AC coupled DVD RF signal input RFIN
8	MA		Analog Input	DC coupled main-beam RF signal input A
9	MB		Analog Input	DC coupled main-beam RF signal input B
10	MC		Analog Input	DC coupled main-beam RF signal input C
11	MD		Analog Input	DC coupled main-beam RF signal input D
12	SA		Analog Input	DC coupled sub-beam RF signal input A
13	SB		Analog Input	DC coupled sub-beam RF signal input B
14	SC		Analog Input	DC coupled sub-beam RF signal input C
15	SD		Analog Input	DC coupled sub-beam RF signal input D
16	CDFON		Analog Input	CD focusing error negative input
17	CDFOP		Analog Input	CD focusing error positive input
18	TNI		Analog Input	3 beam satellite PD signal negative input
19	TPI		Analog Input	3 beam satellite PD signal positive input
ALPC (4)				
20	MDI1		Analog Input	Laser power monitor input
21	MDI2		Analog Input	Laser power monitor input
22	LDO2		Analog Output	Laser driver output
23	LDO1		Analog Output	Laser driver output
Reference Voltage (3)				
28	V2REFO		Analog output	Reference voltage 2.8V

Pin	Main	Ait.	Type	Description
29	V20		Analog output	Reference voltage 2.0V
30	VREFO		Analog output	Reference voltage 1.4V
Analog Monitor Output (7)				
24	SVDD3		Power	Analog power 3.3V
25	CSO	RPOP	Analog output	Central servo Positive main beam summing output
26	RFLVL	RFOV	Analog output	1) RFRP low pass, or Negative main beam summing output
27	SGND		Ground	Analog ground
31	FEO		Analog output	Focus error monitor output
32	TEO		Analog output	Tracking error monitor output
33	TEZISLV		Analog output	TE Slicing Level
Analog Servo Interface (8)				
204	ADCVDD3		Power	Analog 3.3V Power for ADC
205	ADCVSS		Ground	Analog ground for ADC
206	RFVDD3		Power	Analog Power
207	RFRPDC		Analog output	RF ripple detect output
208	RFRPAC		Analog Input	RF ripple detect input(through AC-coupling)
209	HRFZC		Analog Input	High frequency RF ripple zero crossing
210	CRTPLP		Analog output	Defect level filter capacitor connecting
211	RFGND		Ground	Analog Power
RF Data PLL Interface (9)				
195	JITFO		Analog output	The output terminal of RF jitter meter.
196	JITFN		Analog Input	The input terminal of RF jitter meter.
197	PLLVSS		Ground	Ground pin for data PLL and related analog circuitry.
198	IDACEXP		Analog output	Data PLL DAC Low-pass filter
199	PLLVDD3		Power	Power pin for data PLL and related analog circuitry.
200	LPPON		Analog Output	The negative output of loop filter amplifier
201	LPFIP		Analog Input	The positive input terminal of loop filter amplifier.
202	LPFIN		Analog Input	The negative input terminal of loop filter amplifier.
203	LPPOP		Analog Output	The positive output of loop filter amplifier
Motor and Actuator Driver Interface (10)				
34	OP_OUT		Analog output	Op amp output.
35	OP_INN		Analog input	Op amp negative input
36	OP_INP		Analog input	Op amp positive input
37	DMO		Analog Output	Disk motor control output. PWM output.
38	FMO		Analog Output	Feed motor control. PWM output.
39	TROPENPW M		Analog Output	Tray PWM output / Tray open output.
40	PWMOUT1	ADINO	Analog Output	2) 1 st General PWM output, or AD input 0
41	TRO		Analog Output	Tracking servo output. PDM output of tracking servo compensator.

Pin	Main	Alt.	Type	Description
42	FOO		Analog Output	Focus servo output. PDM output of focus servo compensator
43	FG (Digital pin)	ADIN1 GPIO	LVTTL 3.3V Input, Schmitt Input, pull up , with analog input path for ADIN1	1) Motor Hall sensor input, or 2) AD input 1, or 3) GPIO
General Power/Ground (27)				
48,84, 103,133,156	DVDD18		Power	1.8V power pin for internal digital circuitry
71,93,120, 143	DVSS		Ground	1.8V Ground pin for internal digital circuitry
51,63,87, 108,123,138, 151,168	DVDD3		Power	3.3V power pin for internal digital circuitry
57,74,97, 115,130,145, 160	DVSS		Ground	3.3V Ground pin for internal digital circuitry
184	APLLCAP		Analog Inout	APLL External Capacitance connection
183	APLLVSS		Ground	Ground pin for audio clock circuitry
185	APLLVDD3		Power	3.3V Power pin for audio clock circuitry
Micro Controller and Flash Interface (48)				
55	HIGHA0		Inout 4~16MA, SR PU	Microcontroller address 8
68	HIGHA1		Inout 4~16MA, SR PU	Microcontroller address 9
67	HIGHA2		Inout 4~16MA, SR PU	Microcontroller address 10
66	HIGHA3		Inout 4~16MA, SR PU	Microcontroller address 11
65	HIGHA4		Inout 4~16MA, SR PU	Microcontroller address 12
64	HIGHA5		Inout 4~16MA, SR PU	Microcontroller address 13
62	HIGHA6		Inout 4~16MA, SR PU	Microcontroller address 14
61	HIGHA7		Inout 4~16MA, SR PU	Microcontroller address 15
85	AD7		Inout 4~16MA, SR	Microcontroller address/data 7

FOR SZ_MTK USE ONLY

Pin	Main	Alt.	Type	Description
81	AD6		Inout 4~16MA, SR	Microcontroller address/data 6
80	AD5		Inout 4~16MA, SR	Microcontroller address/data 5
79	AD4		Inout 4~16MA, SR	Microcontroller address/data 4
78	AD3		Inout 4~16MA, SR	Microcontroller address/data 3
77	AD2		Inout 4~16MA, SR	Microcontroller address/data 2
76	AD1		Inout 4~16MA, SR	Microcontroller address/data 1
75	AD0		Inout 4~16MA, SR	Microcontroller address/data 0
88	IOA0		Inout 4~16MA, SR PU	Microcontroller address 0 / IO
72	IOA1		Inout 4~16MA, SR PU	Microcontroller address 1 / IO
47	IOA2		Inout 4~16MA, SR PU	Microcontroller address 2 / IO
49	IOA3		Inout 4~16MA, SR PU	Microcontroller address 3 / IO
50	IOA4		Inout 4~16MA, SR PU	Microcontroller address 4 / IO
52	IOA5		Inout 4~16MA, SR PU	Microcontroller address 5 / IO
53	IOA6		Inout 4~16MA, SR PU	Microcontroller address 6 / IO
54	IOA7		Inout 4~16MA, SR PU	Microcontroller address 7 / IO
60	A16		Output 4~16MA, SR PU	Flash address 16
86	A17		Output 4~16MA, SR PU	Flash address 17
56	IOA18		Inout 4~16MA, SR PD, SMT	Flash address 18 / IO
58	IOA19		Inout 4~16MA, SR PD, SMT	Flash address 19 / IO

FOR SZ MTK USE ONLY

Pin	Main	Alt.	Type	Description
69	IOA20		Inout 4~16MA, SR PD, SMT	Flash address 20 / IO
82	IOA21	GPIO	Inout 4~16MA, SR PD, SMT	3) Flash address 21 / IO While External FLASH size <= 2MB: GPIO
83	ALE		Inout 4~16MA, SR PU, SMT	Microcontroller address latch enable
73	IOOE#		Inout 4~16MA, SR SMT	Flash output enable, active low / IO
59	IOWR#		Inout 4~16MA, SR PU, SMT	Flash write enable, active low / IO
70	IOCS#		Inout 4~16MA, SR SMT	Flash chip select, active low / IO
89	UWR#		Inout 4~16MA, SR PU, SMT	Microcontroller write strobe, active low
90	URD#		Inout 4~16MA, SR PU, SMT	Microcontroller read strobe, active low
91	UP1_2		Inout 4MA, SR PU, SMT	Microcontroller port 1-2
92	UP1_3		Inout 4MA, SR PU, SMT	Microcontroller port 1-3
94	UP1_4		Inout 4MA, SR PU, SMT	Microcontroller port 1-4
95	UP1_5		Inout 4MA, SR PU, SMT	Microcontroller port 1-5
96	UP1_6	SCL	Inout 4MA, SR PU, SMT	4) Microcontroller port 1-6 5) I ² C clock pin
98	UP1_7	SDA	Inout 4MA, SR PU, SMT	6) Microcontroller port 1-7 7) I ² C data pin
99	UP3_0	RXD	Inout 4MA, SR PU, SMT	8) Microcontroller port 3-0 9) 8032 RS232 RXD
100	UP3_1	TXD	Inout 4MA, SR PU, SMT	10) Microcontroller port 3-1 11) 8032 RS232 TXD
101	UP3_4	RXD SCL	Inout 4MA, SR PU, SMT	12) Microcontroller port 3-4 13) Hardwired RS232 RXD 14) I ² C clock pin

Pin	Main	Alt.	Type	Description
102	UP3_5	TXD SDA	Inout 4MA, SR PU, SMT	15) Microcontroller port 3-5 16) Hardwired RD232 TXD 17) I ² C data pin
106	IR		Input SMT	IR control signal input
107	INT0#		Inout 4~16MA, SR PU, SMT	Microcontroller external interrupt 0, active low
Audio interface (14)				
163	ALRCK	GPO	Inout 4MA, PD, SMT	1) Audio left/right channel clock Trap value in power-on reset: 1 : use external 373 0 : use internal 373 While internal AUDIO DAC used: GPO
161	ABCK	GPIO	Inout 4MA	2) Audio bit clock 3) While internal AUDIO DAC used: GPIO
162	ACLK	GPIO	Inout 4MA SMT	4) Audio DAC master clock 5) While internal AUDIO DAC used: GPIO
164	ASDATA0	GPO	Inout 4MA PD SMT	6) Audio serial data 0 (Front-Left/Front-Right) Trap value in power-on reset : 1 : manufactory test mode 0 : normal operation While internal AUDIO DAC used: GPO
165	ASDATA1	GPO	Inout 4MA PD SMT	7) Audio serial data 1 (Left-Surround/Right-Surround) Trap value in power-on reset : 1 : manufactory test mode 0 : normal operation While only 2 channels output: GPO
166	ASDATA2	GPO	Inout 4MA PD SMT	8) Audio serial data 2 (Center/LFE) Trap value in power-on reset : 1 : manufactory test mode 0 : normal operation While only 2 channels output: GPO
167	ASDATA3	GPIO	Inout 4MA PD SMT	9) Audio serial data 3 (Center-back/ Center-left-back/Center-right-back, in 6.1 or 7.1 mode) While only 2 channels output: GPIO
169	MC_DATA	INT2# GPIO	Inout 2MA	10) Microphone serial input While not support Microphone: Microcontroller external interrupt 2 GPIO
170	SPDIF		Output 4~16MA, SR : ON/OFF	SPDIF output
186	ADACVDD3		Power	3.3V power pin for AUDIO DAC circuitry
187	AR	GPO	Output	11) AUDIO DAC right channel output 12) While internal AUDIO DAC not used: GPO
188	VCM		Analog	AUDIO DAC reference voltage

Pin	Main	Alt.	Type	Description
189	AL	GPO	Output	13) AUDIO DAC left channel output 14) While internal AUDIO DAC not used: GPO
190	ADACGND		Ground	Ground pin for AUDIO DAC circuitry
Video Interface (12)				
171	DACVDDC		Power	3.3V power pin for VIDEO DAC circuitry
172	VREF		Analog	Bandgap reference voltage
173	FS		Analog	Full scale adjustment
174	DACVSSC		Ground	Ground pin for VIDEO DAC circuitry
175	CVBS		Output 4mA, SR	Analog composite output
176	DACVDDB		Power	3.3V power pin for VIDEO DAC circuitry
177	DACVSSB		Ground	Ground pin for VIDEO DAC circuitry
178	DACVDDA		Power	3.3V power pin for VIDEO DAC circuitry
179	Y/G		Output 4mA, SR	Green or Y or SY or CVBS
180	DACVSSA		Ground	Ground pin for VIDEO DAC circuitry
181	B/CB/PB		Output 4mA, SR	Blue or CB/PB or SC
182	R/CR/PR		Output 4mA, SR	Red or CR/PR or CVBS or SY
MISC (10)				
105	BRST#		Input PU, SMT	Power on reset input, active low
104	ICE		Input PD, SMT	Microcontroller ICE mode enable
193	XTALO		Output	27M crystal out
194	XTALI		Input	27M crystal in
44	GPIO0		Inout 4mA, SR SMT	General purpose IO 0
45	GPIO1	INT4#	Inout 4mA, SR SMT	15) General purpose IO 1 Microcontroller external interrupt 4
46	GPIO2		Inout 2MA	General purpose IO 2
157	GPIO3	INT1#	Inout 2MA	16) General purpose IO 3 17) Microcontroller external interrupt 1
158	GPIO4		Inout 2MA	General purpose IO 4
159	GPIO5	INT3#	Inout 2MA	18) General purpose IO 5 19) Microcontroller external interrupt 3
Dram Interface (38) (Sorted by position)				
155	RA4		Inout	DRAM address 4
154	RA5		Inout	DRAM address 5
153	RA6		Inout	DRAM address 6

Pin	Main	Alt.	Type	Description
152	RA7		Inout	DRAM address 7
150	RA8		Inout	DRAM address 8
149	RA9		Inout	DRAM address 9
148	RA11		Inout Pull-Down	DRAM address bit 11
147	CKE		output	DRAM clock enable
146	RCLK		Inout	Dram clock
144	RA3		Inout	DRAM address 3
142	RA2		Inout	DRAM address 2
141	RA1		Inout	DRAM address 1
140	RA0		Inout	DRAM address 0
139	RA10		Inout	DRAM address 10
137	BA1		Inout	DRAM bank address 1
136	BA0		Inout	DRAM bank address 0
135	RCS#		output	DRAM chip select, active low
134	RAS#		output	DRAM row address strobe, active low
132	CAS#		output	DRAM column address strobe, active low
131	RWE#		output	DRAM Write enable, active low
129	DQM1		Inout	Data mask 1
128	RDB		Inout	DRAM data 8
127	RD9		Inout	DRAM data 9
126	RD10		Inout	DRAM data 10
125	RD11		Inout	DRAM data 11
124	RD12		Inout	DRAM data 12
122	RD13		Inout	DRAM data 13
121	RD14		Inout	DRAM data 14
119	RD15		Inout	DRAM data 15
118	RD0		Inout	DRAM data 0
117	RD1		Inout	DRAM data 1
116	RD2		Inout	DRAM data 2
114	RD3		Inout	DRAM data 3
113	RD4		Inout	DRAM data 4
112	RD5		Inout	DRAM data 5
111	RD6		Inout	DRAM data 6
110	RD7		Inout	DRAM data 7
109	DQM0		Inout	Data mask 0



Version 1.7

MT1389D
Pin Assignment

Specifications are subject to change without notice

Abbr. :

SR : Slew Rate

PU : Pull Up

PD : Pull Down

SMT : Schmitt Trigger

4MA~16MA : Output buffer driving strength.

Pin	Main	Alt.	Type	Description
RF Interface (26)				
191	RFGND18		Ground	Analog ground
192	RFVDD18		Power	Analog power 1.8V
212	OSP		Analog output	RF Offset cancellation capacitor connecting
213	OSN		Analog output	RF Offset cancellation capacitor connecting
214	RFGC		Analog output	RF AGC loop capacitor connecting for DVD-ROM
215	IREF		Analog Input	Current reference input. It generates reference current for RF path. Connect an external 15K resistor to this pin and AVSS.
216	AVDD3		Power	Analog power 3.3V
1	AGND		Ground	Analog ground
2	DVDA		Analog Input	AC coupled input path A
3	DVDB		Analog Input	AC coupled input path B
4	DVDC		Analog Input	AC coupled input path C
5	DVDD		Analog Input	AC coupled input path D
6	DVDRFIP		Analog Input	AC coupled DVD RF signal input RFIP
7	DVDRFIN		Analog Input	AC coupled DVD RF signal input RFIN
8	MA		Analog Input	DC coupled main-beam RF signal input A
9	MB		Analog Input	DC coupled main-beam RF signal input B
10	MC		Analog Input	DC coupled main-beam RF signal input C
11	MD		Analog Input	DC coupled main-beam RF signal input D
12	SA		Analog Input	DC coupled sub-beam RF signal input A
13	SB		Analog Input	DC coupled sub-beam RF signal input B
14	SC		Analog Input	DC coupled sub-beam RF signal input C
15	SD		Analog Input	DC coupled sub-beam RF signal input D
16	CDFON		Analog Input	CD focusing error negative input
17	CDFOP		Analog Input	CD focusing error positive input
18	TNI		Analog Input	3 beam satellite PD signal negative input
19	TPI		Analog Input	3 beam satellite PD signal positive input
ALPC (4)				



Pin	Main	Alt.	Type	Description
20	MDI1		Analog Input	Laser power monitor input
21	MDI2		Analog Input	Laser power monitor input
22	LDO2		Analog Output	Laser driver output
23	LDO1		Analog Output	Laser driver output
Reference Voltage (3)				
28	V2REFO		Analog output	Reference voltage 2.8V
29	V20		Analog output	Reference voltage 2.0V
30	VREFO		Analog output	Reference voltage 1.4V
Analog Monitor Output (7)				
24	SVDD3		Power	Analog power 3.3V
25	CSO	RFOP	Analog output	1) Central servo 2) Positive main beam summing output
26	RFLVL	RFON	Analog output	1) RFRP low pass, or 2) Negative main beam summing output
27	SGND		Ground	Analog ground
31	FEO		Analog output	Focus error monitor output
32	TEO		Analog output	Tracking error monitor output
33	TEZISLV		Analog output	TE Slicing Level
Analog Servo Interface (8)				
204	ADCVDD3		Power	Analog 3.3V Power for ADC
205	ADCVSS		Ground	Analog ground for ADC
206	RFVDD3		Power	Analog Power
207	RFRPDC		Analog output	RF ripple detect output
208	RFRPAC		Analog Input	RF ripple detect input(through AC-coupling)
209	HRFZC		Analog Input	High frequency RF ripple zero crossing
210	CRTPLP		Analog output	Defect level filter capacitor connecting
211	RFGND		Ground	Analog Power
RF Data PLL Interface (9)				
195	JITFO		Analog output	The output terminal of RF jitter meter.
196	JITFN		Analog Input	The input terminal of RF jitter meter.
197	PLLVSS		Ground	Ground pin for data PLL and related analog circuitry.
198	IDACEXP		Analog output	Data PLL DAC Low-pass filter
199	PLLVDD3		Power	Power pin for data PLL and related analog circuitry.
200	LPFON		Analog Output	The negative output of loop filter amplifier
201	LPFIP		Analog Input	The positive input terminal of loop filter amplifier.
202	LPFIN		Analog Input	The negative input terminal of loop filter amplifier.
203	LPFOP		Analog Output	The positive output of loop filter amplifier



Pin	Main	Alt.	Type	Description
Motor and Actuator Driver Interface (10)				
34	OP_OUT		Analog output	Op amp output.
35	OP_INN		Analog input	Op amp negative input
36	OP_INP		Analog input	Op amp positive input
37	DMO		Analog Output	Disk motor control output. PWM output.
38	FMO		Analog Output	Feed motor control. PWM output.
39	TROPENPW M		Analog Output	Tray PWM output / Tray open output.
40	PWMOUT1	ADIN0	Analog Output	1) 1 st General PWM output, or 2) AD input 0
41	TRO		Analog Output	Tracking servo output. PDM output of tracking servo compensator.
42	FOO		Analog Output	Focus servo output. PDM output of focus servo compensator
43	FG (Diogital pin)	ADIN1 GPIO	LVTTL 3.3V Input, Schmitt Input, pull up , with analog input path for ADIN1	1) Motor Hall sensor Input, or 2) AD input 1, or 3) GPIO
General Power/Ground (27)				
48,84, 103,133,156	DVDD18		Power	1.8V power pin for internal digital circuitry
71,93,120, 143	DVSS		Ground	1.8V Ground pin for internal digital circuitry
58,61,87, 108,123,138, 151,168	DVDD3		Power	3.3V power pin for internal digital circuitry
56,74,97, 115,130,145, 160	DVSS		Ground	3.3V Ground pin for internal digital circuitry
184	APLLCAP		Analog Inout	APLL External Capacitance connection
185	APLLVSS		Ground	Ground pin for audio clock circuitry
183	APLLVDD3		Power	3.3V Power pin for audio clock circuitry
Micro Controller and Flash Interface (48)				
54	HIGHA0		Inout 4~16MA, SR PU	Microcontroller address 8
68	HIGHA1		Inout 4~16MA, SR PU	Microcontroller address 9
67	HIGHA2		Inout 4~16MA, SR PU	Microcontroller address 10



Pin	Main	Alt.	Type	Description
66	HIGHA3		Inout 4~16MA, SR PU	Microcontroller address 11
65	HIGHA4		Inout 4~16MA, SR PU	Microcontroller address 12
64	HIGHA5		Inout 4~16MA, SR PU	Microcontroller address 13
63	HIGHA6		Inout 4~16MA, SR PU	Microcontroller address 14
62	HIGHA7		Inout 4~16MA, SR PU	Microcontroller address 15
85	AD7		Inout 4~16MA, SR	Microcontroller address/data 7
81	AD6		Inout 4~16MA, SR	Microcontroller address/data 6
80	AD5		Inout 4~16MA, SR	Microcontroller address/data 5
79	AD4		Inout 4~16MA, SR	Microcontroller address/data 4
78	AD3		Inout 4~16MA, SR	Microcontroller address/data 3
77	AD2		Inout 4~16MA, SR	Microcontroller address/data 2
76	AD1		Inout 4~16MA, SR	Microcontroller address/data 1
75	AD0		Inout 4~16MA, SR	Microcontroller address/data 0
88	IOA0		Inout 4~16MA, SR PU	Microcontroller address 0 / IO
72	IOA1		Inout 4~16MA, SR PU	Microcontroller address 1 / IO
47	IOA2		Inout 4~16MA, SR PU	Microcontroller address 2 / IO
49	IOA3		Inout 4~16MA, SR PU	Microcontroller address 3 / IO
50	IOA4		Inout 4~16MA, SR PU	Microcontroller address 4 / IO



Pin	Main	Alt.	Type	Description
51	IOA5		Inout 4~16MA, SR PU	Microcontroller address 5 / IO
52	IOA6		Inout 4~16MA, SR PU	Microcontroller address 6 / IO
53	IOA7		Inout 4~16MA, SR PU	Microcontroller address 7 / IO
60	A16		Output 4~16MA, SR PU	Flash address 16
86	A17		Output 4~16MA, SR PU	Flash address 17
55	IOA18		Inout 4~16MA, SR PD, SMT	Flash address 18 / IO
57	IOA19		Inout 4~16MA, SR PD, SMT	Flash address 19 / IO
69	IOA20		Inout 4~16MA, SR PD, SMT	Flash address 20 / IO
82	IOA21	GPIO	Inout 4~16MA, SR PD, SMT	1) Flash address 21 / IO 2) While External FLASH size <= 2MB: GPIO
83	ALE		Inout 4~16MA, SR PU, SMT	Microcontroller address latch enable
73	IOOE#		Inout 4~16MA, SR SMT	Flash output enable, active low / IO
59	IOWR#		Inout 4~16MA, SR PU, SMT	Flash write enable, active low / IO
70	IOCS#		Inout 4~16MA, SR SMT	Flash chip select, active low / IO
89	UWR#		Inout 4~16MA, SR PU, SMT	Microcontroller write strobe, active low
90	URD#		Inout 4~16MA, SR PU, SMT	Microcontroller read strobe, active low



Pin	Main	Alt.	Type	Description
91	UP1_2		Inout 4MA, SR PU, SMT	Microcontroller port 1-2
92	UP1_3		Inout 4MA, SR PU, SMT	Microcontroller port 1-3
94	UP1_4		Inout 4MA, SR PU, SMT	Microcontroller port 1-4
95	UP1_5		Inout 4MA, SR PU, SMT	Microcontroller port 1-5
96	UP1_6	SCL	Inout 4MA, SR PU, SMT	1) Microcontroller port 1-6 2) I ² C clock pin
98	UP1_7	SDA	Inout 4MA, SR PU, SMT	1) Microcontroller port 1-7 2) I ² C data pin
99	UP3_0	RXD	Inout 4MA, SR PU, SMT	1) Microcontroller port 3-0 2) 8032 RS232 RXD
100	UP3_1	TXD	Inout 4MA, SR PU, SMT	1) Microcontroller port 3-1 2) 8032 RS232 TXD
101	UP3_4	RXD SCL	Inout 4MA, SR PU, SMT	1) Microcontroller port 3-4 2) Hardwired RD232 RXD 3) I ² C clock pin
102	UP3_5	TXD SDA	Inout 4MA, SR PU, SMT	1) Microcontroller port 3-5 2) Hardwired RD232 TXD 3) I ² C data pin
106	IR		Input SMT	IR control signal input
107	INT0#		Inout 4~16MA, SR PU, SMT	Microcontroller external interrupt 0, active low
Audio interface (14)				
163	ALRCK	GPO	Inout 4MA, PD, SMT	1) Audio left/right channel clock 2) Trap value in power-on reset: I) 1 : use external 373 II) 0 : use internal 373 3) While internal AUDIO DAC used: GPO
161	ABCK	GPIO	Inout 4MA	1) Audio bit clock 2) While internal AUDIO DAC used: GPIO



Pin	Main	Alt.	Type	Description
162	ACLK	GPIO	Inout 4MA SMT	1) Audio DAC master clock 2) While internal AUDIO DAC used: GPIO
164	ASDATA0	GPO	Inout 4MA PD SMT	1) Audio serial data 0 (Front-Left/Front-Right) 2) Trap value in power-on reset : I) 1 : manufactory test mode II) 0 : normal operation 3) While internal AUDIO DAC used: GPIO
165	ASDATA1	GPO	Inout 4MA PD SMT	1) Audio serial data 1 (Left-Surround/Right-Surround) 2) Trap value in power-on reset : I) 1 : manufactory test mode II) 0 : normal operation 3) While only 2 channels output: GPO
166	ASDATA2	GPO	Inout 4MA PD SMT	1) Audio serial data 2 (Center/LFE) 2) Trap value in power-on reset : I) 1 : manufactory test mode II) 0 : normal operation 3) While only 2 channels output: GPO
167	ASDATA3	GPIO	Inout 4MA PD SMT	1) Audio serial data 3 (Center-back/ Center-left-back/Center-right-back, in 6.1 or 7.1 mode) 2) While only 2 channels output: GPIO
169	MC_DATA	INT2# GPIO	Input 2MA	1) Microphone serial input 2) While not support Microphone: I) Microcontroller external interrupt 2 II) GPIO
170	SPDIF		Output 4~16MA, SR : ON/OFF	SPDIF output
186	ADACVDD3		Power	3.3V power pin for AUDIO DAC circuitry
187	AR	GPO	Output	1) AUDIO DAC right channel output 2) While internal AUDIO DAC not used: GPO
188	VCM		Analog	AUDIO DAC reference voltage
189	AL	GPO	Output	1) AUDIO DAC left channel output 2) While internal AUDIO DAC not used: GPO
190	ADACGND		Ground	Ground pin for AUDIO DAC circuitry
Video Interface (12)				
171	DACVDDC		Power	3.3V power pin for VIDEO DAC circuitry
172	VREF		Analog	Bandgap reference voltage
173	FS		Analog	Full scale adjustment
174	DACVSSC		Ground	Ground pin for VIDEO DAC circuitry
175	CVBS		Output 4MA, SR	Analog composite output
176	DACVDDB		Power	3.3V power pin for VIDEO DAC circuitry
177	DACVSSB		Ground	Ground pin for VIDEO DAC circuitry
178	DACVDDA		Power	3.3V power pin for VIDEO DAC circuitry

Pin	Main	Alt.	Type	Description
179	Y/G		Output 4MA, SR	Green or Y or SY or CVBS
180	DACVSSA		Ground	Ground pin for VIDEO DAC circuitry
181	B/CB/PB		Output 4MA, SR	Blue or CB/PB or SC
182	R/CR/PR		Output 4MA, SR	Red or CR/PR or CVBS or SY
MISC (10)				
105	PRST#		Input PU, SMT	Power on reset input, active low
104	ICE		Input PD, SMT	Microcontroller ICE mode enable
193	XTALO		Output	27M crystal out
194	XTALI		Input	27M crystal in
44	GPIO0		Inout 4MA, SR SMT	General purpose IO 0
45	GPIO1	INT4#	Inout 4MA, SR SMT	1) General purpose IO 1 2) Microcontroller external interrupt 4
46	GPIO2		Inout 2MA	General purpose IO 2
157	GPIO3	INT1#	Inout 2MA	1) General purpose IO 3 2) Microcontroller external interrupt 1
158	GPIO4		Inout 2MA	General purpose IO 4
159	GPIO5	INT3#	Inout 2MA	1) General purpose IO 5 2) Microcontroller external interrupt 3
Dram Interface (38) (Sorted by position)				
155	RA4		Inout	DRAM address 4
154	RA5		Inout	DRAM address 5
153	RA6		Inout	DRAM address 6
152	RA7		Inout	DRAM address 7
150	RA8		Inout	DRAM address 8
149	RA9		Inout	DRAM address 9
148	RA11		Inout Pull-Down	DRAM address bit 11
147	CKE		output	DRAM clock enable
146	RCLK		Inout	Dram clock
144	RA3		Inout	DRAM address 3
142	RA2		Inout	DRAM address 2
141	RA1		Inout	DRAM address 1

Pin	Main	Alt.	Type	Description
140	RA0		Inout	DRAM address 0
139	RA10		Inout	DRAM address 10
137	BA1		Inout	DRAM bank address 1
136	BA0		Inout	DRAM bank address 0
135	RCS#		output	DRAM chip select, active low
134	RAS#		output	DRAM row address strobe, active low
132	CAS#		output	DRAM column address strobe, active low
131	RWE#		output	DRAM Write enable, active low
129	DQM1		Inout	Data mask 1
128	RD8		Inout	DRAM data 8
127	RD9		Inout	DRAM data 9
126	RD10		Inout	DRAM data 10
125	RD11		Inout	DRAM data 11
124	RD12		Inout	DRAM data 12
122	RD13		Inout	DRAM data 13
121	RD14		Inout	DRAM data 14
119	RD15		Inout	DRAM data 15
118	RDO		Inout	DRAM data 0
117	RD1		Inout	DRAM data 1
116	RD2		Inout	DRAM data 2
114	RD3		Inout	DRAM data 3
113	RD4		Inout	DRAM data 4
112	RD5		Inout	DRAM data 5
111	RD6		Inout	DRAM data 6
110	RD7		Inout	DRAM data 7
109	DQM0		Inout	Data mask 0

Note:

- The Main column is the main function, Alt. Means alternative function.
- The multi-function GPIO pins are set to green characters.
- The multi-function GPO pins are set to blue characters.
- The external TV encoder mode only supports CCIR-656 mode.
- Compare to MT1389B/MT1389C,
 GPIO0 <--> VSYN
 GPIO1 <--> HSYN
 GPIO2 <--> SPMCLK
 GPIO3 <--> SPDATA
 GPIO4 <--> SPLRCK
 GPIO5 <--> SPBCK
- bonding option
 pin 93 optional to GPIO6 <--> YUV7
 pin 103 optional to GPIO7 <--> ASDATA4

Revision History:

Date	Version	Content
------	---------	---------



2004-01-10	1.0	● Document Initial
2004-02-10	1.1	● Pin re-define
2004-02-13	1.2	● Pin 86 change to A17, Pin 87 change to DVDD3
2004-02-16	1.3	● Pin 161 change to ABCK, Pin162 change to ACLK, Pin 163 change to ALRCK ● Pin 182 add SY or CVBS output, Pin 180 add SC output, Pin 179 add CVBS or SY output
2004-02-18	1.4	● Reverse video dac pin order (pin179 ~ pin190)
2004-02-19	1.5	● Remove RA11 as GPIO ● Change ACLK, ASDATA0, ASDATA1, ASDATA2 GPIO function to GPO only ● Change video dac, audio dac, apll pin position
2004-03-01	1.6	● Change pin APLLVD3 to pin 183, pin APLLVS to pin 185
2004-03-02	1.7	● Change pin 51 ~ pin 63 assignment

Release to Mission Right

2.2 Power Supply Circuit Diagram and Component Layout

Fig2-2 Power Supply Circuit Diagram

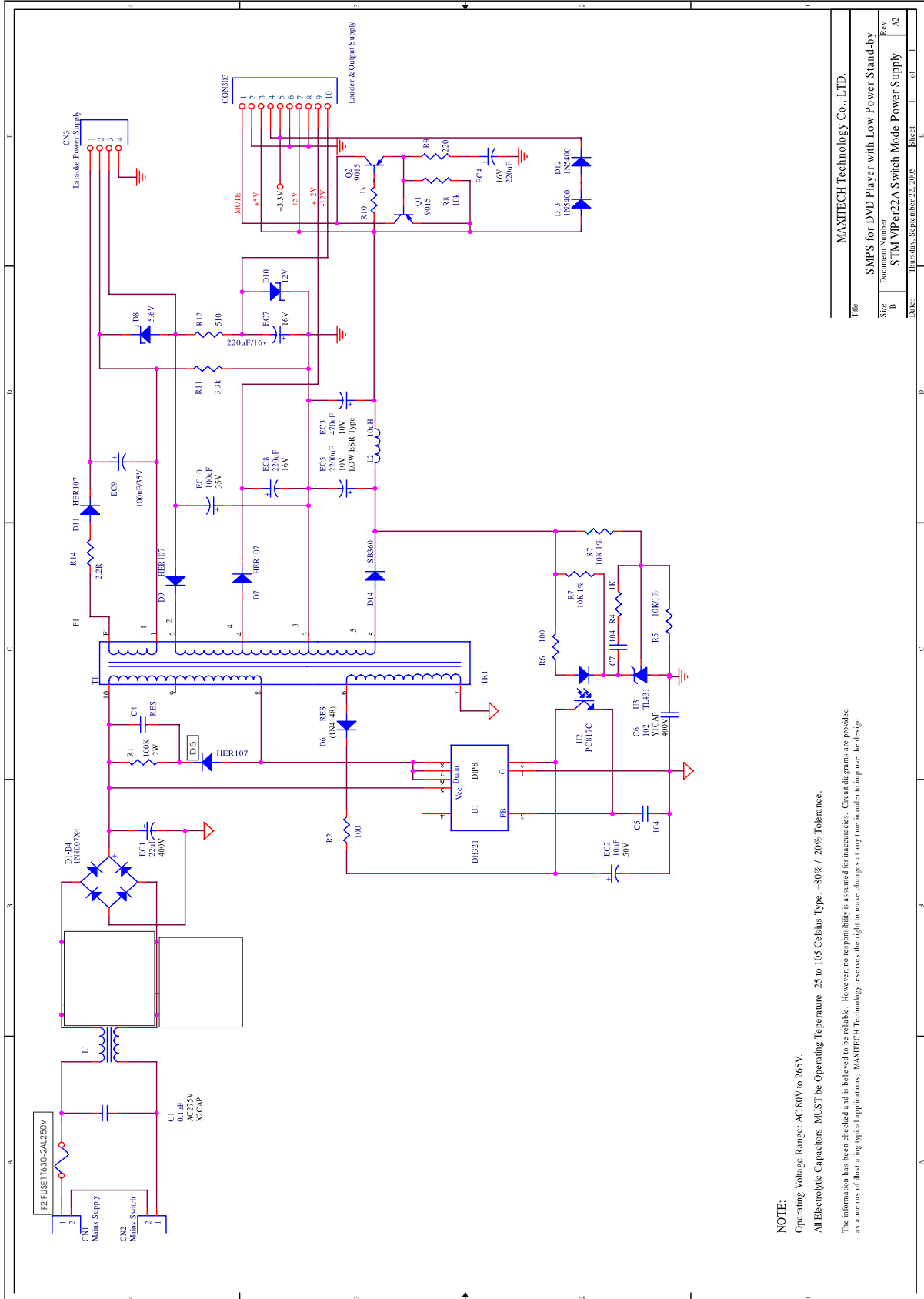

NOTE:

Operating Voltage Range: AC 80V to 265V.

All Electrolytic Capacitors MUST be Operating Temperature -25 to 105 Celsius Type: +80% / -20% Tolerance.

The information has been checked and is believed to be reliable. However, no responsibility is assumed for inaccuracies. Circuit diagrams are provided as a means of illustrating typical applications. MAXTECH Technology reserves the right to make changes at any time in order to improve the design.

Type:		MAXTECH Technology Co., LTD.	
Size	Document Number	SMPS for DYD Player with Low Power Stand-by	
B	D	Rev	A2
Date:	Thursday, September 22, 2005	Sheet	1 of 1

Fig2-3 Power Supply Assembly Drawing

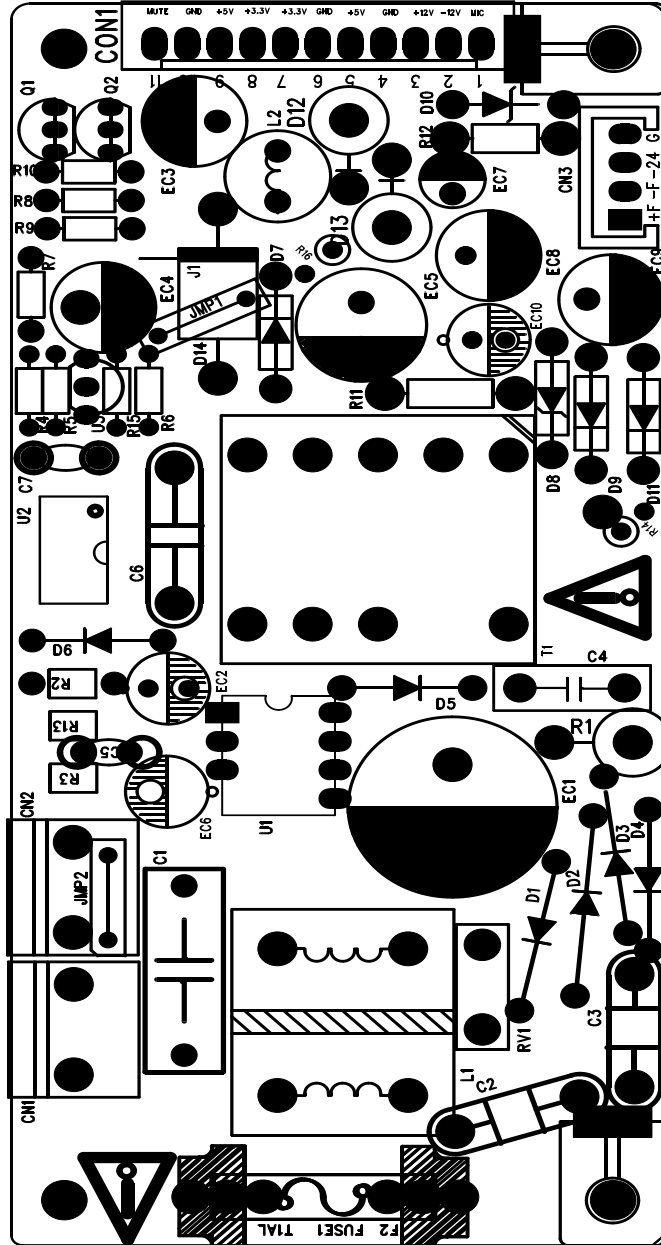

Fig2-4 Power Supply Bottom Routing

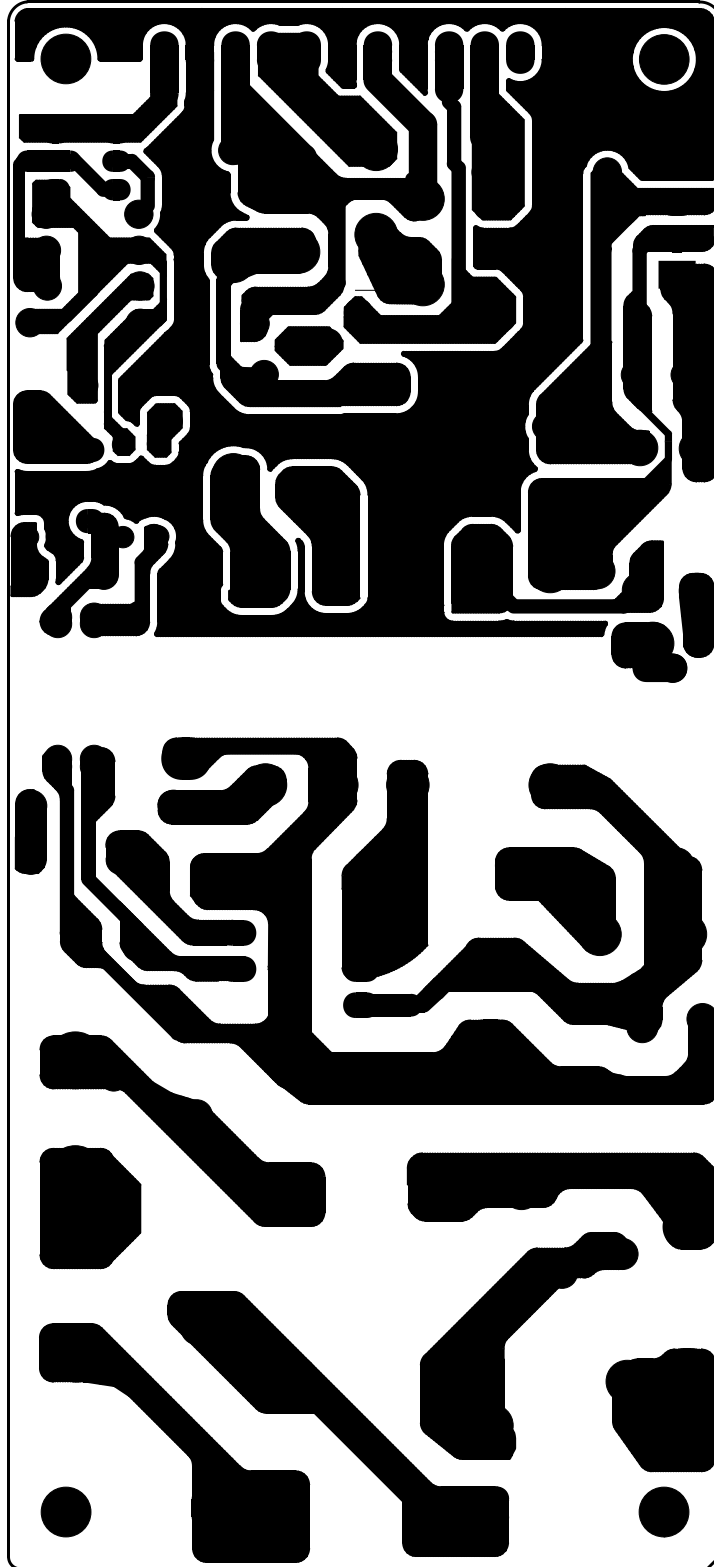
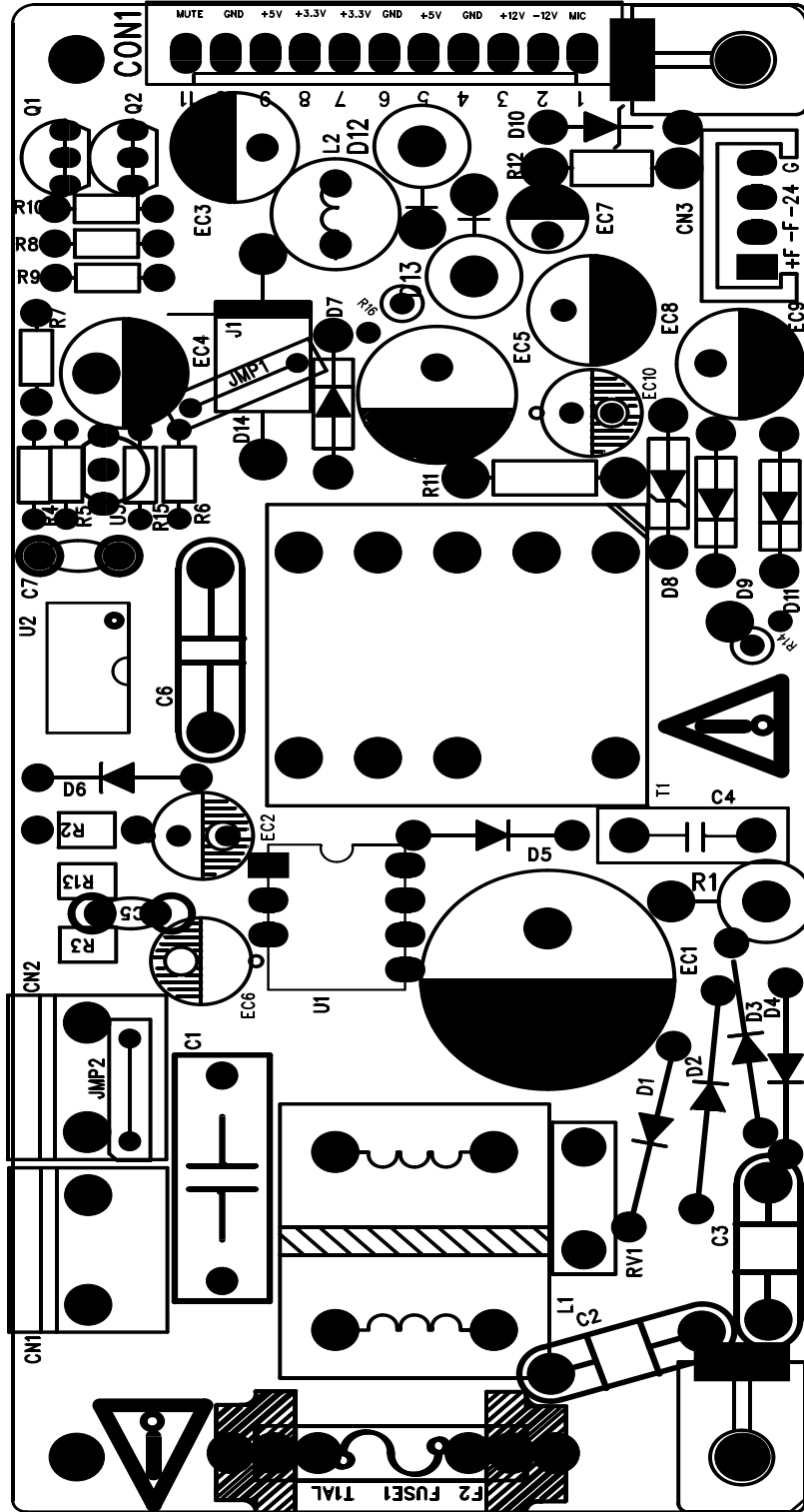

Fig2-3 Power Supply Assembly Drawing



MR89EM6-11.1

MT1389E DVD Demo Board for SANYO HD60 PUH

- 1 INDEX & POWER, RESET
- 2 RF / SERVO / MPEG - MT1389D
- 3 MEMORY - SDRAM, FLASH/EEPROM
- 4 VIDEO FILTER
- 5 AUDIO FILTER

NAME	TYPE	DEVICE
VCC	Digital 5V	SUPPLY
DVDD	Digital 3.2V	MT1389E
RFVDD	Servo 3.3V	MT1389E
LDO_AVDD	Laser Diode 3-3V	
AVCC	RF 5V	PICKUP HEADDR
V18	Digital 1.8V	MT1389E
SDVDD	Digital 3.2V	SDRAM
+12V	Audio +12V	OP AMP.
-12V	Audio -12V	OP AMP.
AVDD	Audio 5V	Audio DAC
DVDD	Audio 5V	Audio DAC

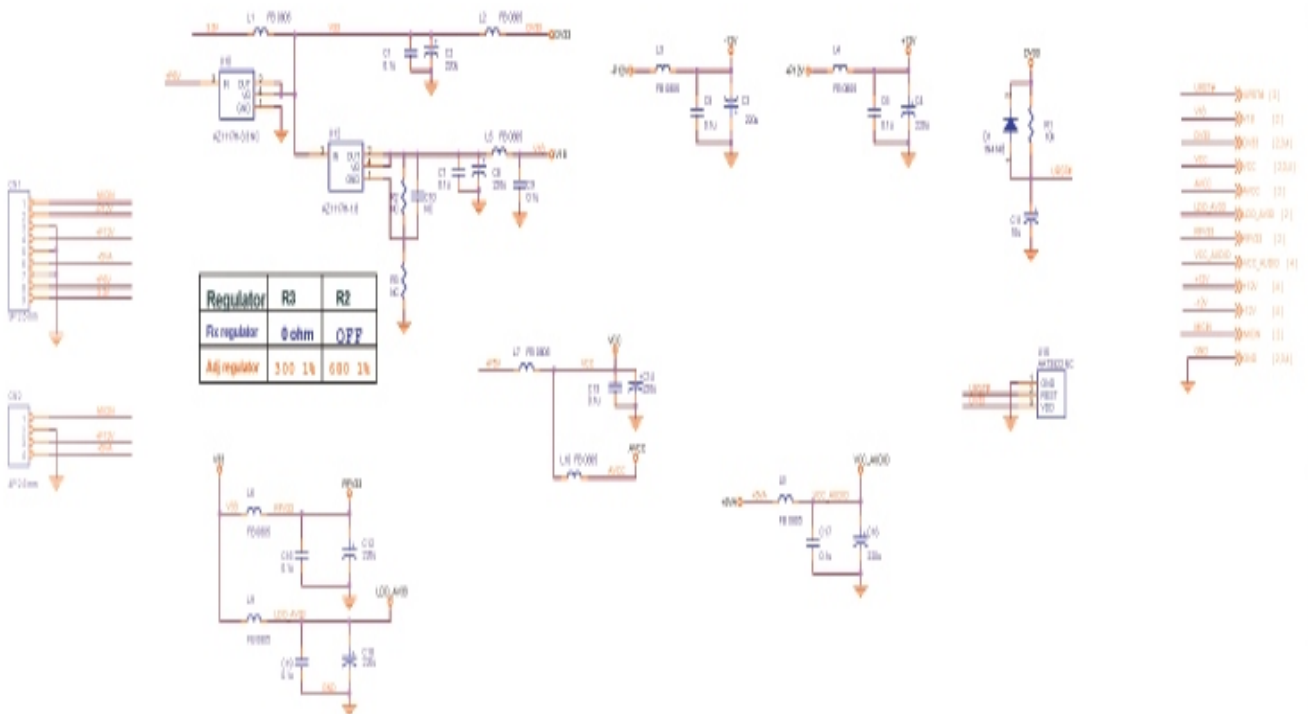

Mediatek Incorporation
 COMMON89D_HD60_V3
 Description: POWER & RESET
 Rev: 1.0

MT1389E

Pin Assignment v1.4

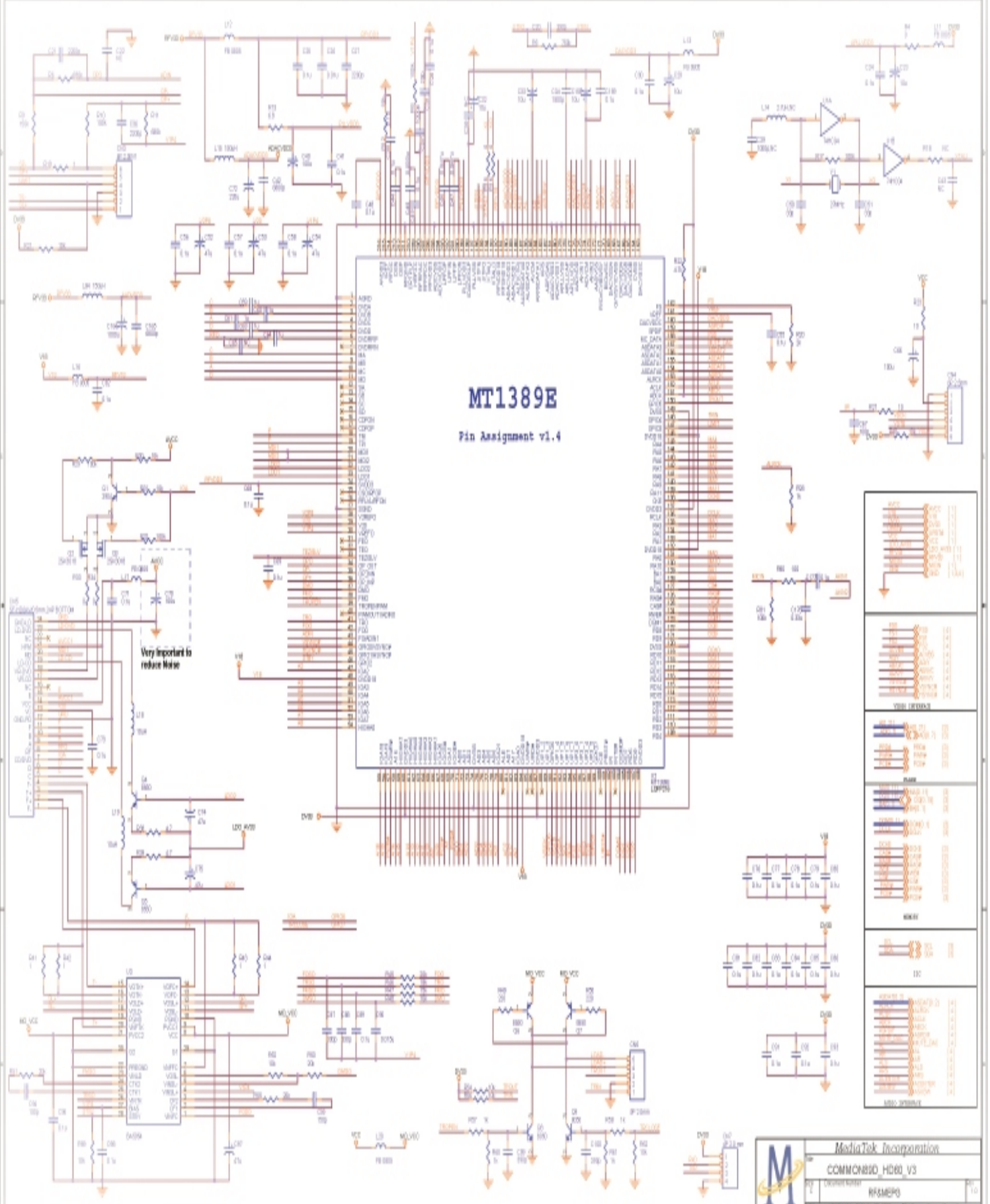

Very important to reduce Noise

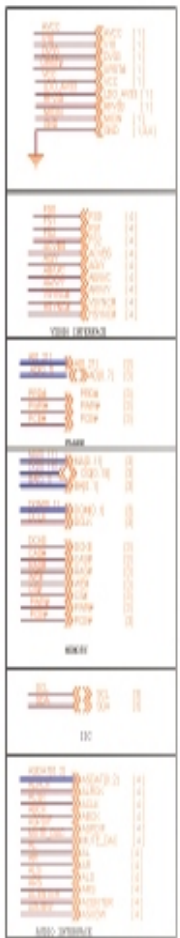

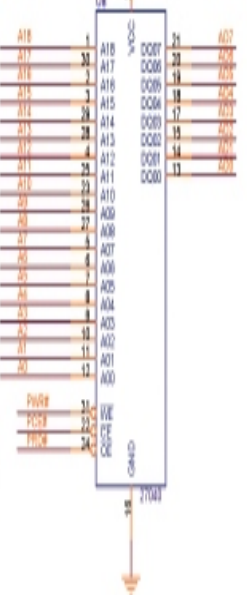
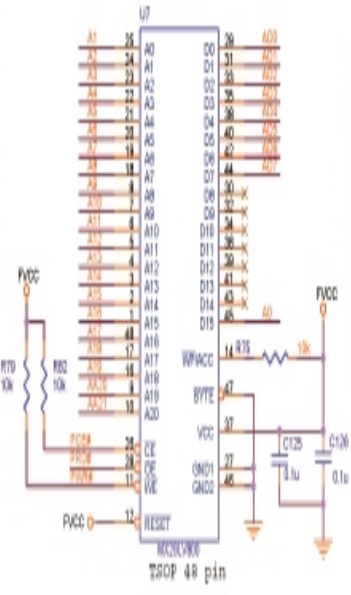
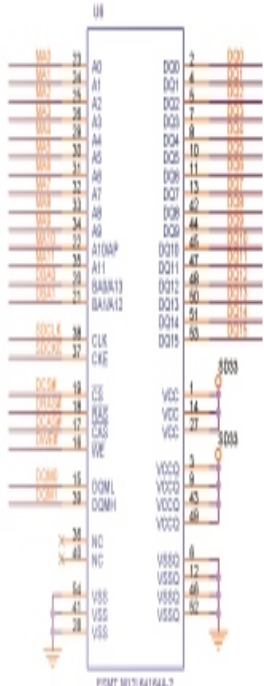
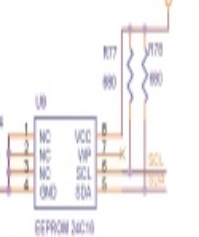
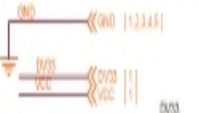
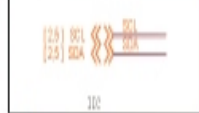
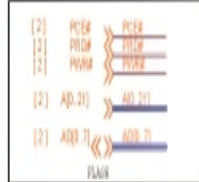
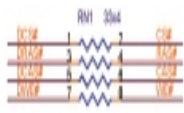
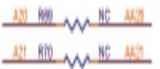
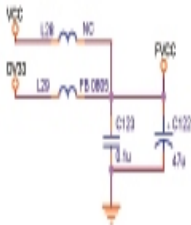
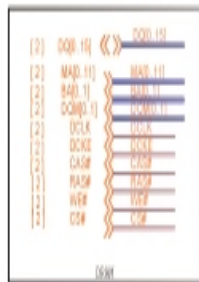
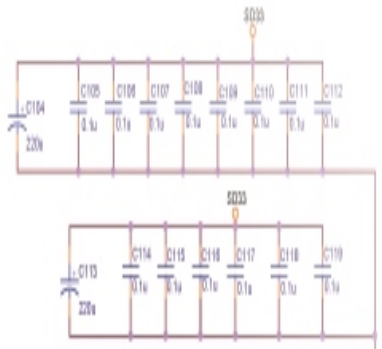

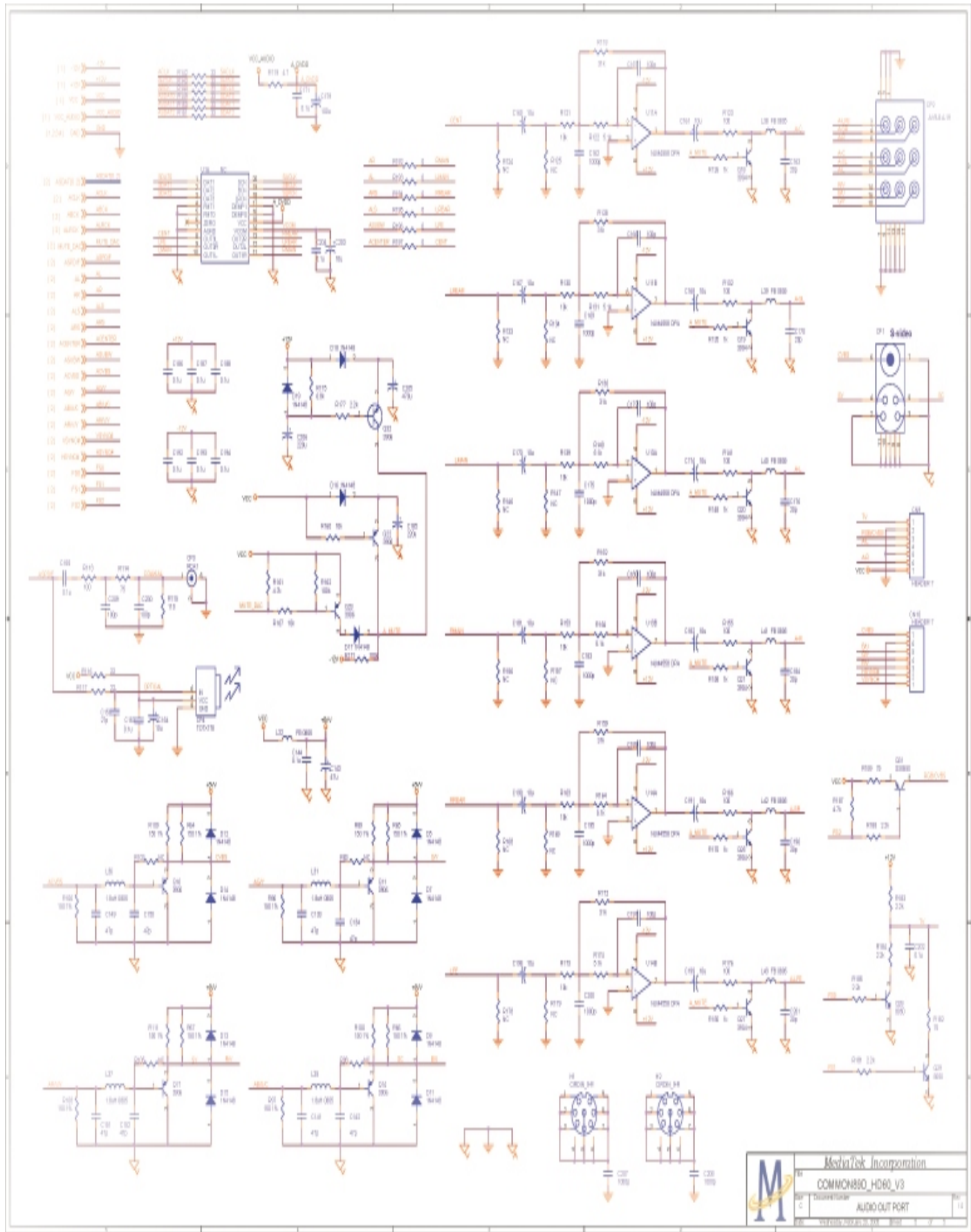

Materials List

Part Name	Front Panel PCB Assy		Modul		DVD4797 Front board)	
	2005-2-15	QS2-DVD928-001A	1	PCS		
二	Part name					
	CR02	221	4		R3, R5, R12, R15	
		511	1		R16	
		1000	5		R7, R10, R11, R14, R17	
		4.7K	5		R1, R2, R6, R8, R9	
		10K	1		R13	
		51K	1		R4	
		27P	3		C6, C7, C8	
		104	6		C2, C4, C5, C9, C10, C1	
		105	1		C3	
		9014	2		Q2, Q1	
		100UF/10V	3		CD1, CD2, CD3, C1	
3		HM838-14	1		I1R1	
4	LED	φ3LED	1		LED1	
		φ3LED)	1		LED3	
	LEDDisplay	ZDC-2004UYB-A	1	PCS		
	Chip IC					
		PT6964-S	1	PCS	IU1	
	Connector	R-7CX-7JX-150mm	1	PCS		

Materials List

		Part No ED-DAE02-02	Modul		
	2005-8-15	DVD928-SCART	1	PCS	
	R Carbon Film	330R	2		2R8, 2R9
		910R	1		2R18
		121R	2		R1, R10
		331R	1		R13
		821R	2		R14, R9
		1K	5		R3, U1, 2R1, 2R14, 2R17
		1K2	1		2R2
		3K3	1		2R16
		4K7	1		2R12
		7K5	1		2R13
		10K	3		2R3, 2R10, 2R15
		390K	1		2R5
		1M	1		2R11
		4.7KX3	1		R4
		10P	1		2C5
		104	1		2C8
		10UF/16V	4		2C3, 2C9, 2C10, 2C11
		100UF/16V	2		2C6 2C7
		IN4148	2		2V4, 2V5
		8550	1		2V3
		8050	3		2V1, 2V2, 2V6
		9014	3		Q1, Q2, Q4
		() 4558	1		2N1
		φ6.35-20	2		MIC1
	SCART piug	21PIN	1		CP1
		RVO9N-B10K-15F-F	1		2RV1
		2JX-2CX-160mm	1		
		R-9CX-9JX-150mm	1		
		R-9CX-9JX-140mm	1		
			1		4CON5
			7		JMP1~JMP4, JMP8~JMP10
			3		JMP5~JMP7

Materials List

Power PCB Assy	Part No EDDAE02-03	Modul			
一	RA00-100R	1	PCS	±5%	R6
	RA00-220R	1	PCS	±5%	R9
	RA00-1K	3	PCS	±5%	R4 R10 R15
	RA00-4K7	2	PCS	±5%	R5 R7
	RA00-10K	1	PCS	±5%	R8
	RA00-1R	2	PCS	±5%	R16, R12
	RA00-47R	1	PCS	±5%	R2
	RA00-1K	1	PCS	±5%	D10
	RA00-68K	1	PCS	±5%	R1
二					
	104	2			C5 C7
	103	1			C4
	102/400V AC	1			C6
	104/275V AC	1		±15mm	
		1		10UF/50V 20% EC2	
		2		EC10%	
		1		100UF/25V 20% EC8	
		1		470UF/10V 20% EC4	
		1		1000UF/10V 20% EC3	
		1		2200UF/10V 20% EC5	
		1		22UF/400V 20% EC1	
		IN4007	4		D1 D2 D3 D4
		HER107	4		D5 D6 D7 D9
		HER303	1		D14
		9015	2		Q1 Q2
		20uH	1		L2
		70mH	1		L1, 30uH
	DVD-321B	1		T1	
	KA431AZ	1		U3	
	PC817B	1		U2	
	DH321	1		U1	
		2		FUSE1	
	250V T1AL	1			
		2		CN1 CN2	
		1		CON1	
	QSI-DH321	1		2005.09.15 VER:A	

Materials List

Part Name	Front Panel PCB Assy	Mdcl	
CR02	0R(0603)	11	R15 R16 R33 R34 R69 R192 R193 R194 R195 R196 R197
CR02	1R(0603)	5	R19 R41 R42 R43 R44
CR02	4.7R(0603)	2	R38 R39
CR02	6.8R(0603)	1	R13
CR02	10R(0603)	1	R27
CR02	22R(0603)	2	R116 R117
CR02	33R(0603)	4	R71 R72 R73 R74
CR02	75R(0603)	1	R114
CR02	100R(0603)	2	R84 R113
CR02	110R(0603)	1	R115
CR02	150R(0603)	14	R63 R66 R67 R65 R64 R98 R100 R111 R89 R109 R106 R86 R108 R97
CR02	200R(0603)	1	R3
CR02	220R(0603)	2	R49 R50
CR02	390R(0603)	1	R2
CR02	470R(0603)	9	R57 R58 R81 R123 R132 R141 R155 R166 R176
CR02	680R(0603)	2	R77 R78
CR02	750R(0603)	1	R80
CR02	1K(0603)	9	R28 R60 R61 R126 R135 R148 R158 R170 R180
CR02	2.2K(0603)	1	R85
CR02	2K(0603)	1	R20
CR02	4.7K(0603)	2	R35 R22
CR02	5.1K(0603)	6	R122 R131 R140 R154 R164 R174
CR02	6.8K(0603)	1	R87
CR02	10K(0603)	24	R30 R31 R40 R62 R68 R76 R59 R75 R79 R52 R48 R21 R54 R56 R26 R37
			R121 R130 R139 R153 R163 R173 R82 R25
CR02	15K(0603)	2	R47 R12
CR02	18K(0603)	1	R46
CR02	20K(0603)	4	R51 R53 R55 R45
CR02	30K(0603)	6	R118 R128 R136 R152 R159 R172
CR02	100K(0603)	7	R17 R29 R32 R36 R7 R8 R70
CR02	150K(0603)	2	R9 R10
CR02	680K(0603)	2	R6 R11
CR02	750K(0603)	1	R5
	33R*4(0603)	1	RN1
	0R(0805)	7	L7 L38 L39 L40 L41 L42 L43
	1R(0805)	1	R23
	100R(0805)	2	L3 L4
	10P	2	C139 C140
	20P(0603)	7	C31 C163 C170 C176 C184 C196 C201
	27P(0603)	3	C50 C51 C156
	47P(0603)	8	C133 C134 C141 C142 C149 C150 C151 C152
	101(0603)	9	C67 C157 C166 C172 C180 C189 C197 C209 C230
	151(0603)	2	C94 C95
	331(0603)	2	C87 C88
	391(0603)	3	C20 C99 C100
	102(0603)	9	C37 C162 C169 C175 C183 C195 C200 C207 C208
	152(0603)	1	C34

3.1. Power Supply Trouble Service Flow Chart

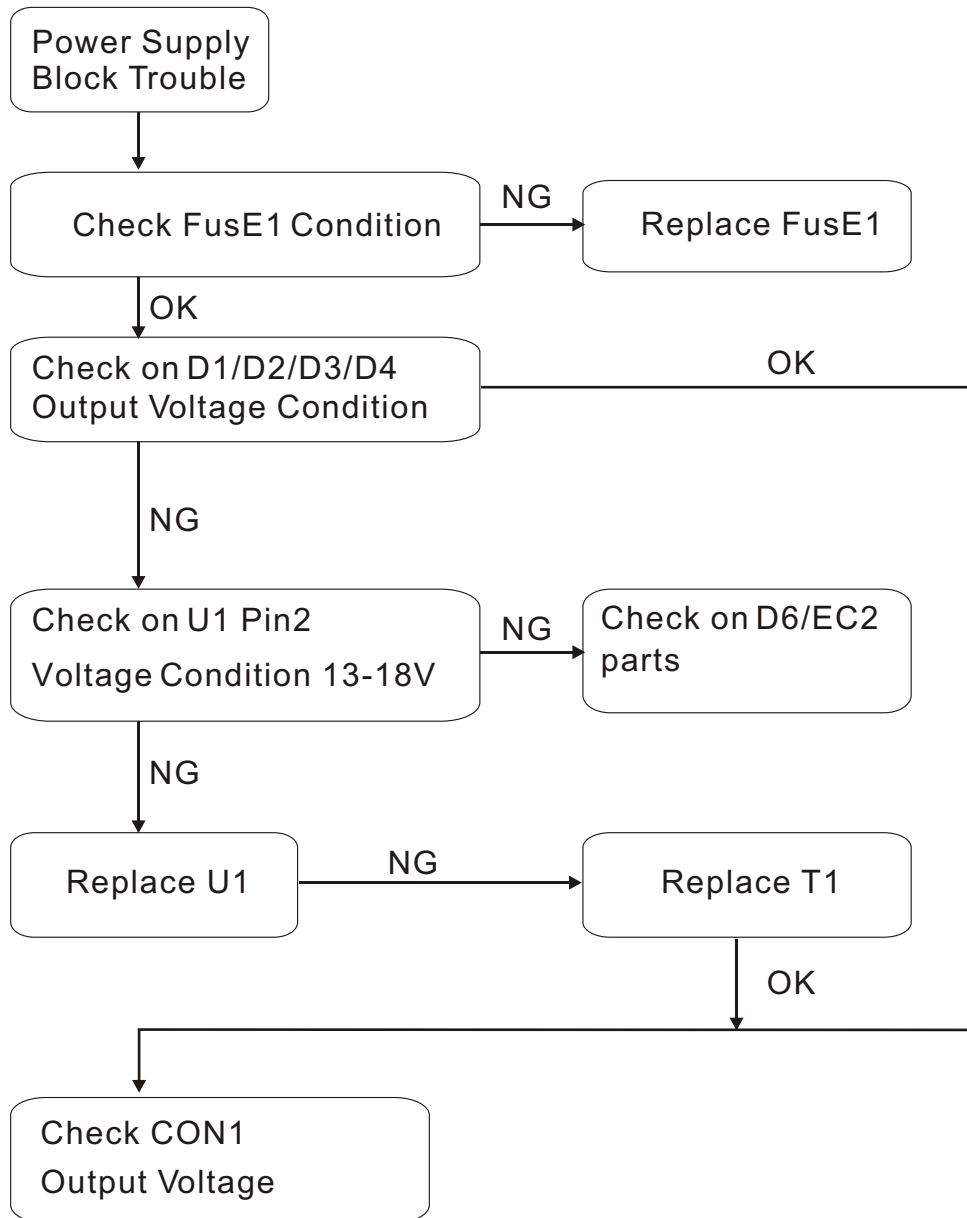

3.2. Read Disc Trouble Service Flow Chart

Read disc problem in a DVD player is a very complicated issue that may involve complex issues. This problem is not only relation to the electronic circuit, but also very much relation to the operation environment.

DVD loading unit is a very complicate part that contains big number of ESD components , which require specific equipment, tools and technique to repair; In general, service technician is not suggested to disassemble the DVD loading unit. It is suggest proving the trouble and replacing the complete DVD loading unit, instead of repairing the DVD loading unit in local workshop.

It is suggested to prove the faulty of a DVD loading unit by replacement by a good DVD loading unit.

Before checking the “NO DISC” Trouble, ensure excluding the following possibilities:

The test disc is damage.

AC power supply voltage dropped below the minimum required level.

DVD disc region code and color system is not matching to the DVD player or system setting.

Moisture condensed inside the unit. (Power on the unit, without disc loaded, for 1 / 2 to 2 hours).

Service Flow Chart

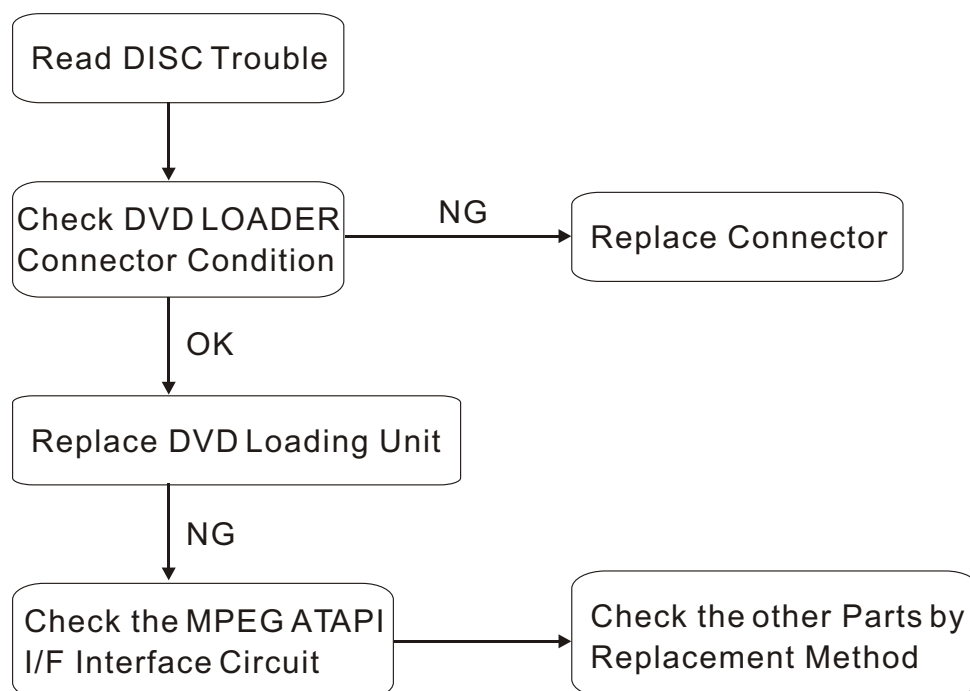

3.3. Video Trouble Service Flow Chart

3.3.1. Composite Video Trouble Service Flow Chart

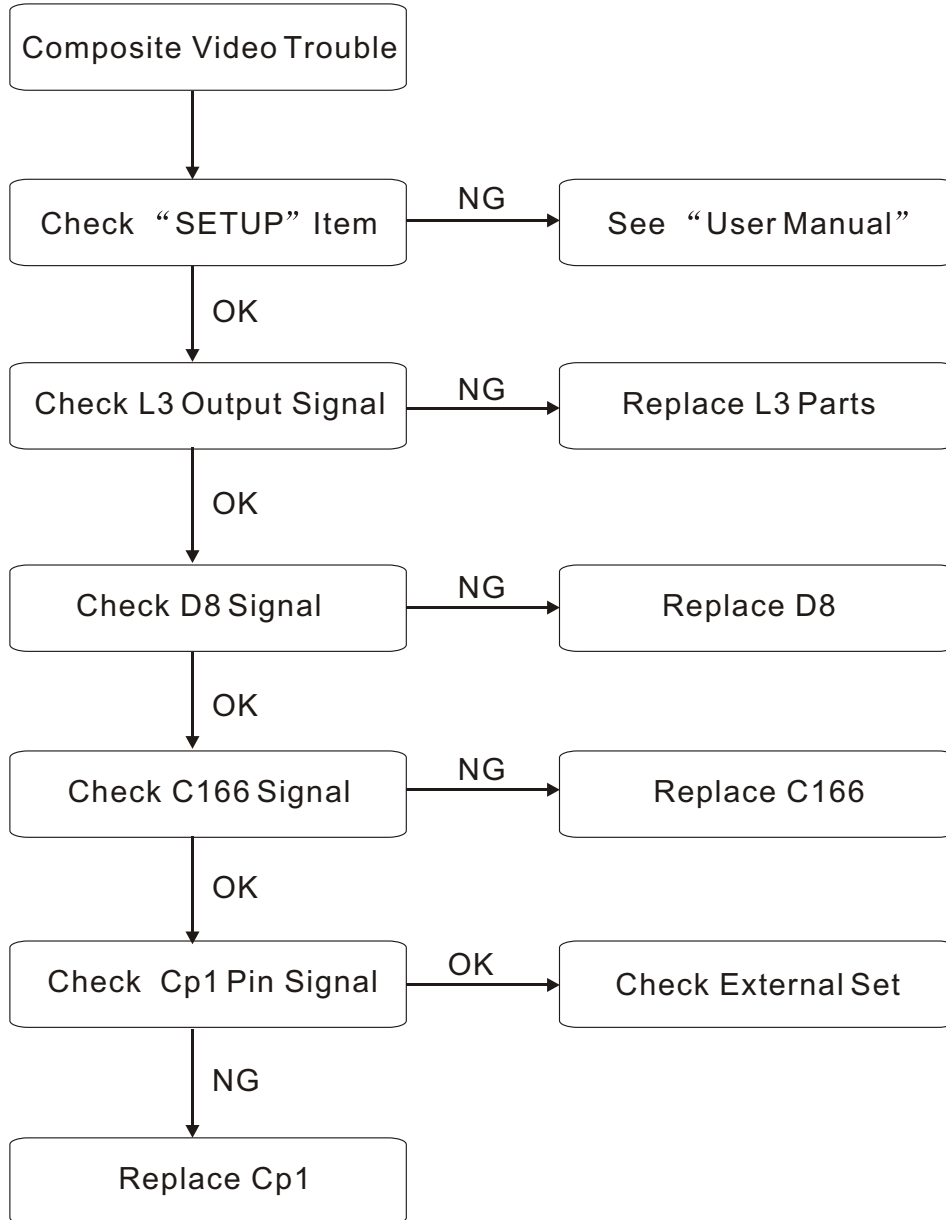

∅*12mm			C190 C191 C198 C199
∅*12mm	10F/16V	1	C101
∅*12mm	47F/10V	9	C52 C53 C54 C74 C75 C97 C122 C120 C143
∅*12mm	100F/10V	3	C40 C66 C70
∅6*12mm	220F/10V	8	C2 C8 C12 C14 C18 C42 C104 C129
∅6*12mm	220F/16V	3	C3 C4 C133
∅7*12mm	470F/16V	1	C130
∅8*12mm	1000F/10V	1	C22
	1.8H	5	L31 L34 L35 L36 L37
	10H	2	L18 L19
	150H	2	L15 L21
	3.3H	1	L9
805	FB012601	13+1	I2 I5 I6 I10 I11 I12 I13 I16 I17 I20 I32 I27 I28
	M448	15	D2 D4 D5 D6 D7 D8 D9 D10 D11 D12 D13 D14 D15 D16 D17
	S800	2	Q8 Q9
	S850	2	Q6 Q7
	9014	1	Q2
	3004	7	Q1 Q18 Q19 Q20 Q21 Q25 Q27
	3006	8	Q11 Q12 Q14 Q16 Q17 Q23 Q24 Q28
	2K3018	2	Q2 Q3
	2B1132	2	Q1 Q5
	27.000MHz	1	
	AZ1117-ADJ(1A)	2	U10 U12
	F458	3	U11 U13 U14
	24C16	1	U9
	H57M161610IC-7	1	U5
	MT1389E/E	1	U15
	BA554M	1	U3
	AT498192AT	1	U7
	10PIN	1	CN7
	2PIN	1	CN9
	3PIN	1	CN6
	6PIN	1	CN3
	7PIN	1	CN1
	9PIN	2	CN2 CN4
	2PIN	1	CN5
	AV6-8 4-7A	1	AV1
	AV4-8 4-7A	1	AV2
	SI03	1	AV3
	Q2-MT1389E-SCART	1	Ver:A 2005-7-26

3.5. Digital Audio Trouble Service Flow Chart

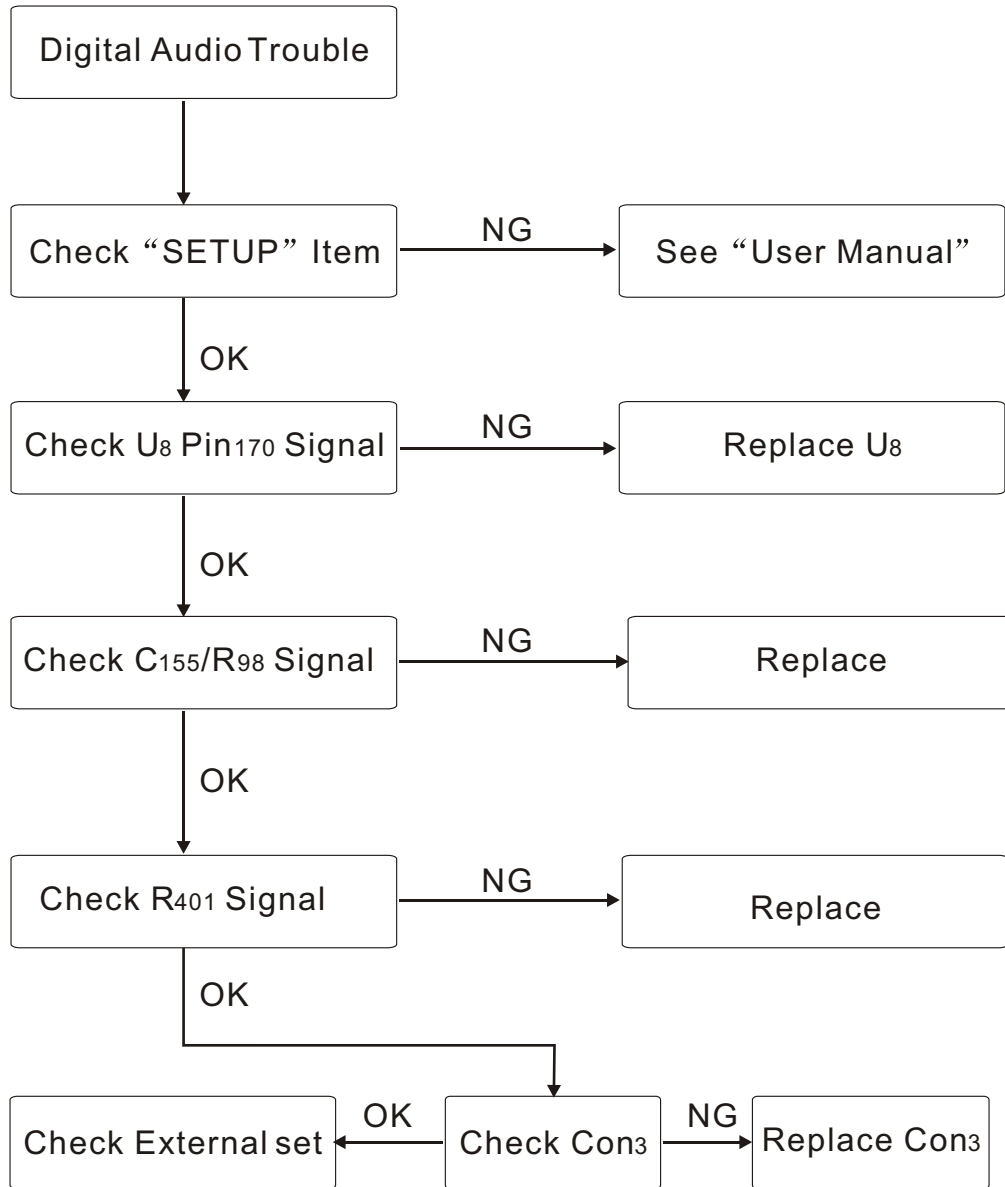

3.6. Front Control Trouble Service Flow Chart

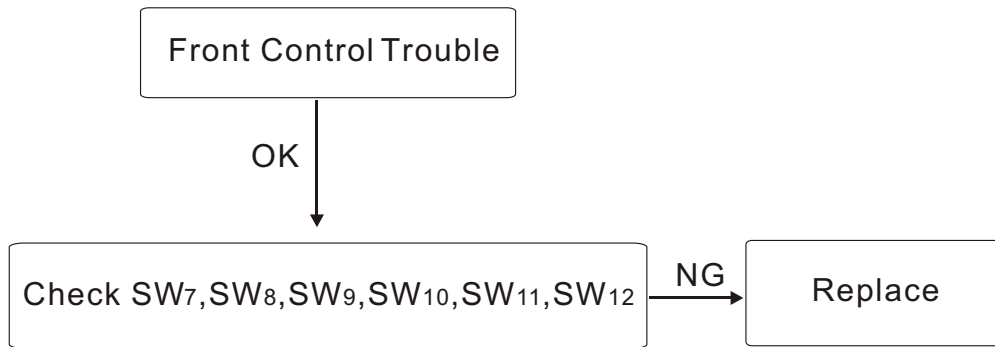

3.7. Remote Control Trouble Service Flow Chart

